

ARTICLE 4 ZONING DISTRICTS

SEC. 4.1 ESTABLISHMENT OF DISTRICTS

For the purpose of this Zoning Ordinance, the area of jurisdiction of this Zoning Ordinance is hereby divided into zoning districts which shall be designated as follows:

Districts	New	Page
Agriculture District	AG	4-4
Single Family Residential Districts	R-E RR RS-1A RS-1B RS-1C RS-1D	4-6
Manufactured Housing Subdivision	MHS	4-7
Mobile Home Park	MHP	4-7
Two-Family Residential District	RM-2	4-22
Townhouse/Multi-Family Residential District	RM-3	4-22
Multifamily Residential District	RM-4	4-22
Neighborhood Business District	NB	4-33
General Business District	GB	4-33
Central Business District	CB	4-33
Highway Business District	HB	4-33
Office and Professional - Residential	OP-R	4-33
Office and Professional - Commercial	OP-C	
Public District	P	4-33
Light Industrial District	LI	4-61
Heavy Industrial District	HI	4-61
Planned Unit Development District	PUD	4-67
General Flood District	F	4-68
Urban Growth Overlay District	UG	4-72
Local Historic District, Local Historic Site	H	4-93
Conservation District	C	4-93
University District	UD	4-94
Rural Village Overlay District	V	4-95
Airport Overlay District	A	4-99

SEC. 4.2 OFFICIAL ZONING MAP

4.2.1 Established

The boundaries of these zoning districts are hereby established on Official Zoning Map entitled "Zoning Map - Bowling Green Corporate Limits," dated March, 1958, as amended and "Zoning Maps - Warren County," dated October, 1967, as amended, which shall both be permanently located in the City-County Planning Commission offices. These official zoning maps together with all explanatory matter thereon, are hereby adopted by reference and declared to be a part of this Zoning Ordinance. Any territory hereafter annexed to any city shall remain in the same district as legally existed before annexation unless the district is specifically changed by ordinance according to the requirements of the relevant provisions of KRS or this Zoning Ordinance pertaining to amendments.

4.2.2 Replacement

In the event that either Official Zoning Map becomes damaged, destroyed, lost, or is deemed necessary to be replaced due to age of the map, the City-County Planning Commission may by authorization through resolution adopted by the Cities of Bowling Green, Plum Springs, Woodburn, Oakland, Smiths Grove and Warren County, adopt a new Official Zoning Map which shall supersede the prior Official Zoning Map. The new Official Zoning Map may correct drafting or other errors or omissions in the prior Official Zoning Map, but no such correction shall have the effect of amending the original Official Zoning Map or any subsequent amendment thereof. Unless the prior Official Zoning Map has been lost, or has been totally destroyed, the prior map or any significant parts thereof remaining, shall be preserved, together with all available records pertaining to its adoption or amendment.

4.2.3 Rules for Interpretation of Zoning District Boundaries

The zoning district boundary lines on the Official Zoning Map are intended to follow lot or tract lines or farm boundaries, the center lines of streets or the corporate limit lines, all as they existed at the time of enactment of this Ordinance. Where uncertainty exists as to the boundaries of Zoning Districts as shown on the Official Zoning Map, the following rules shall apply.

- A.** Boundaries indicated as approximately following the center lines of streets, highways or alleys shall be construed to follow such center lines; vacated rights-of-way shall not effect the original zoning.
- B.** Boundaries indicated as approximately following platted lot lines shall be construed as following such lot lines.
- C.** Boundaries indicated as approximately following political boundaries shall be construed as following such boundaries.
- D.** Boundaries indicated as following railroad lines or rights-of-way shall be construed to be midway between the main tracks.
- E.** Boundaries indicated as following shore lines shall be construed to follow such shore lines, and in the event of change in the shore line shall be construed as moving with the actual shore line; boundaries indicated as approximately following the center lines of streams, rivers, lakes or other bodies of water shall be construed to follow such center lines.

Article 4

Zoning Districts – General

- F.** Boundaries indicated as approximately parallel to features indicated in the paragraphs above shall be so construed. Distances not specifically indicated on the Official Zoning Map shall be determined by the scale of the map, if an accurate legal description cannot be determined.

- G.** Where the above stated rules do not indicate the exact location of the zoning district boundaries, then said boundaries shall be determined by the Executive Director and may be subject to appeal to the Board of Adjustments.

SEC. 4.3 AGRICULTURE DISTRICT (AG)

4.3.1 Purpose and Intent

The Agriculture District is intended to:

- A. Maintain, preserve and enhance the prime agriculture lands of Warren County;
- B. Protect the decreasing supply of prime agriculture lands in Warren County in order to maintain one of the county's principal economic resources--the agriculture economy of the county;
- C. Discourage premature urban growth on land best suited for agriculture purposes;
- D. Control the indiscriminate infiltration of urban development into prime agriculture areas which adversely affects agriculture operators;
- E. Minimize urban-type development in rural areas until urban-type services and utilities can be provided;
- F. Preserve the natural beauty and open space character of the rural countryside.
- G. Protect the public health, safety and welfare from hazardous and/or unsafe waste, whether solid, semi-solid or liquid generated or disintegrated from a municipal, commercial or industrial waste water treatment plant, water supply treatment plant, air pollution control facility or any other such waste having similar characteristics and effects; due to the presence of sinkholes, losing streams and sinking streams associated with the karst topography of Warren County.

4.3.2 Uses

Uses permitted in this District are shown in the Use Table in Sec. 5.1, Use Table. This table employs broad use categories containing a variety of similar uses. The use categories are described in Sec. 5.2, Use Categories, and Appendix B lists examples of uses, showing which use categories they fall into. Additional standards for specific uses, if any, can be found in each category.

4.3.3 Permitted Residential Unit Types

The following residential unit types shall be permitted in this District:

- A. Single-family detached;
- B. Modular home;
- C. Manufactured home; and
- D. Mobile Home (on lots with a minimum area of 5 acres).

Article 4

Zoning Districts – Agriculture

4.3.4 Property Development Standards

- A. Dimensional standards for this District are found in the following table. Residential development, less than two (2) acres in size, in this District shall comply with the single family residential development standards in Sec. 4.4. Only one principal residential structure shall be permitted per platted lot.

- B. Exception (in Warren County unincorporated area only). The minimum lot area for this District may be reduced to one acre for no more than 2 lots being subdivided from a parcel which has existed in the same configuration since July 1, 2001. The remaining parcel must be a minimum of no less than five (5) acres and meet the minimum district requirements outlined in chart below.

Agriculture District (AG)

4.3.5 Signs

Agricultural uses and properly permitted conditional uses may have a maximum of one freestanding sign (pole or monument) with a maximum face area of 50 s.f. and maximum height of 15 feet. Additional wall signs are allowed at a maximum total sign face of 50 s.f. No sign shall be externally or internally illuminated. All permitted signs shall also comply with all the applicable Sign Development Standards in Section 4.6.8.F.

Lot Area (minimum) Public Sewer *	217,800 SF
Septic System *	217,800 SF
Lot Width (minimum) (at building line)	100 feet
Lot Frontage (minimum) Public Street Cul-de-Sac (bulb only)	40 feet 40 feet
Lot Coverage (maximum)	25%
Setbacks (minimum) Front Yard Side Yard Warren Co. unincorporated Rear Yard Accessory Structure -- Rear -- Side	25 feet 25 feet 10 feet 25 feet 5 feet 5 feet
Height (maximum)	N/A
Fire Protection Required?	Yes, with exceptions **
Off-Street Parking	2 spaces

* See exception in Sec. 4.3.4.B.

** Large agricultural tracts of 10 acres or greater in size are exempt from the fire protection requirements. See Sec. 1.13.

Article 4

Zoning Districts – Single Family Residential

SEC. 4.4 SINGLE FAMILY RESIDENTIAL DISTRICTS

4.4.1 Rural Residential District (RR) (Warren County unincorporated area only)

A. Purpose and Intent

The Rural Residential District provides opportunities for large lot residential development in the unincorporated areas of Warren County only.

B. Permitted Residential Unit Types

The following residential unit types shall be permitted in this District:

1. Single-family detached;
2. Modular home;
3. Manufactured home; and
4. Mobile home.

4.4.2 Residential Estate District (R-E)

A. Purpose and Intent

The Residential Estate District is intended to provide opportunities for large-lot rural estates in areas that may or may not be served by public sanitary sewer. This area is intended to serve as a transition between urban and rural areas.

B. Permitted Residential Unit Types

The following residential unit types shall be permitted in this District:

1. Single-family detached;
2. Modular home; and
3. Manufactured home.

4.4.3 RS-1A through RS-1D

A. Purpose and Intent

The Single Family Residential Districts are intended to provide opportunities for detached single family residential development, including zero lot line homes. Occupancy in these districts is limited to one family per residential unit. No accessory apartments shall be allowed in these districts. These districts shall be served by public sanitary sewer.

B. Permitted Residential Unit Types

The following residential unit types shall be permitted in these Districts:

	RS-1A	RS-1B	RS-1C	RS-1D
Single-Family Detached	P	P	P	P
Modular Home	P	P	P	P
Manufactured Home	--	--	--	P
Zero Lot Line	--	--	P	P

P= Permitted Type

Article 4

Zoning Districts – Single Family Residential

4.4.4 Manufactured Home Subdivision (MHS)

A. Purpose and Intent

The Manufactured Housing Subdivision District is intended to provide housing development opportunities for single and double wide manufactured homes. This district shall be served by public sanitary sewer.

B. Permitted Residential Unit Types

The following residential unit types shall be permitted in this District:

1. Single-family detached;
2. Modular Home; and
3. Manufactured home.

4.4.5 Mobile Home Park (MHP)

A. Purpose and Intent

The Mobile Home Park District is intended to:

1. Recognize the mobile home as a form of housing for which specific provisions should be made and provide for the development of properly located and planned facilities for mobile home lots.
2. Provide a desirable residential environment, protect the mobile home park from potentially adverse neighboring influences, protect adjacent residential properties, and provide access to public facilities equivalent to that provided to other forms of permitted residential development.
3. Recognize that in urban and urbanizing areas of Warren County, mobile homes should be located in mobile home parks and that such areas shall be carefully located and designed to meet the needs of the residents and to achieve a satisfactory relationship with surrounding neighborhoods. This district shall be served by public sanitary sewer.

B. Permitted Residential Unit Types

The following residential unit types shall be permitted in this District:

1. Manufactured home; and
2. Mobile home.

4.4.6 General Residential Development Standards

A. Uses

Uses permitted in each District are shown in the Use Table in Sec. 5.1. This table employs broad use categories containing a variety of similar uses. The use categories are described in Sec. 5.2, Use Categories, and Appendix B lists examples of uses, showing which use categories they fall into. Additional standards for specific uses, if any, can be found in each category.

Article 4

Zoning Districts – Single Family Residential

B. Property Development Standards

Only one principal residential unit shall be allowed per platted lot in the RE, RR, RS, and MHS districts. Development in each District shall comply with the general residential development standards in the following table:

	RR	R-E	RS-1A	RS-1B	RS-1C	RS-1D	MHS	MHP
Lot Area (min sf)								*
Public Sewer	2 acres	43,560	13,500	11,000	8,000	5,000	8,000	217,800
Septic System	2 acres	43,560	N/A	N/A	N/A	N/A	N/A	N/A
Lot Width (min lf) (at building line)	100	100	85	75	60	50	60	50
Lot Frontage (min lf)								
Public Street	50	50	50	50	50	50	50	50
Cul-de-sac (bulb only)	40	40	40	40	32	32	32	40
Lot Coverage (max)	25%	25%	40%	50%	60%	70%	50%	N/A
Setbacks (min lf)								
Front Yard	25	25	25	25	25	25	25	50*
Side Yard	25	10	10	7.5	7.5	5	7.5	25*
Rear Yard	25	25	10	10	10	10	25	25*
Accessory Structure	5	5	5	5	5	5	5	5
Height (max ft)	35	42	42	42	42	42	35	35
Fire Protection Required? (Sec. 6.3)	Yes	Yes	Yes	Yes	Yes	Yes	Yes	Yes
County Standard	250 GPM	250 GPM	250 GPM	250 GPM	250 GPM	250 GPM	250 GPM	250 GPM
City of BG Standard	NA	600 GPM	600 GPM	600 GPM	600 GPM	600 GPM	600 GPM	600 GPM
Parking spaces required	2	2	2	2	2	2	2	2

* For specific MHP space standards, see 4.4.7.c.

Article 4

Zoning Districts – Single Family Residential

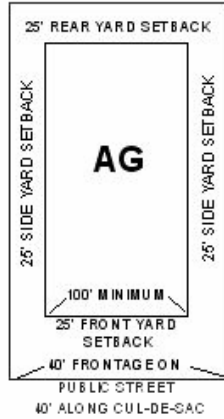

AGRICULTURAL DISTRICT

LOT AREA, MINIMUM	
<i>PUBLIC SEWER</i>	N/A
<i>SEPTIC SYSTEM</i>	217,800SF
MAXIMUM LOT COVERAGE	25%
MAXIMUM BUILDING HEIGHT	N/A

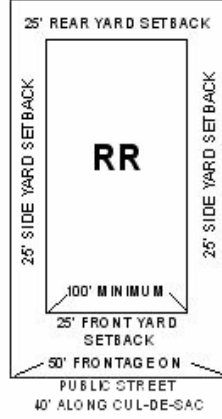

RURAL RESIDENTIAL DISTRICT

LOT AREA, MINIMUM	
<i>PUBLIC SEWER</i>	87,120 SF
<i>SEPTIC SYSTEM</i>	87,120 SF
MAXIMUM LOT COVERAGE	25%
MAXIMUM BUILDING HEIGHT	35'

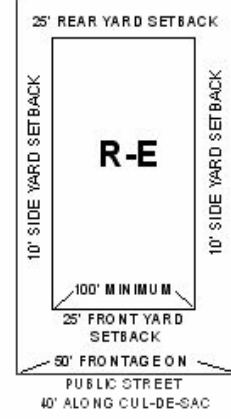

R-E SINGLE FAMILY DISTRICT

LOT AREA, MINIMUM	
<i>PUBLIC SEWER</i>	43,560 SF
<i>SEPTIC SYSTEM</i>	43,560 SF
MAXIMUM LOT COVERAGE	25%
MAXIMUM BUILDING HEIGHT	42'

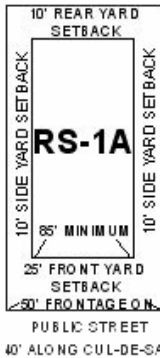

RS-1A SINGLE FAMILY DISTRICT

LOT AREA, MINIMUM	
<i>PUBLIC SEWER</i>	13,500 SF
<i>SEPTIC SYSTEM</i>	N/A
MAXIMUM LOT COVERAGE	40%
MAXIMUM BUILDING HEIGHT	42'

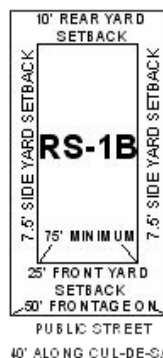

RS-1B SINGLE FAMILY DISTRICT

LOT AREA, MINIMUM	
<i>PUBLIC SEWER</i>	11,000 SF
<i>SEPTIC SYSTEM</i>	N/A
MAXIMUM LOT COVERAGE	50%
MAXIMUM BUILDING HEIGHT	42'

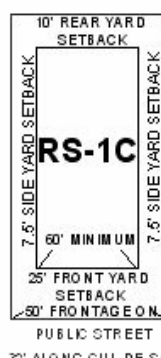

RS-1C SINGLE FAMILY DISTRICT

LOT AREA, MINIMUM	
<i>PUBLIC SEWER</i>	8,000 SF
<i>SEPTIC SYSTEM</i>	N/A
MAXIMUM LOT COVERAGE	60%
MAXIMUM BUILDING HEIGHT	42'

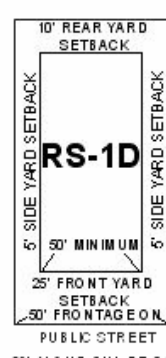

RS-1D SINGLE FAMILY DISTRICT

LOT AREA, MINIMUM	
<i>PUBLIC SEWER</i>	5,000 SF
<i>SEPTIC SYSTEM</i>	N/A
MAXIMUM LOT COVERAGE	70%
MAXIMUM BUILDING HEIGHT	42'

LOT DIMENSIONAL STANDARDS FOR RESIDENTIAL LOTS WITH CORRESPONDING SETBACKS

Article 4

Zoning Districts – Single Family Residential

C. Other Standards

1. **Corner lots.** Corner lots shall be required to provide a front yard along any lot line abutting a street. Unless the plat is expressly marked as to the street the dwelling will front on, a rear yard shall be substituted for any side yard not abutting a street.

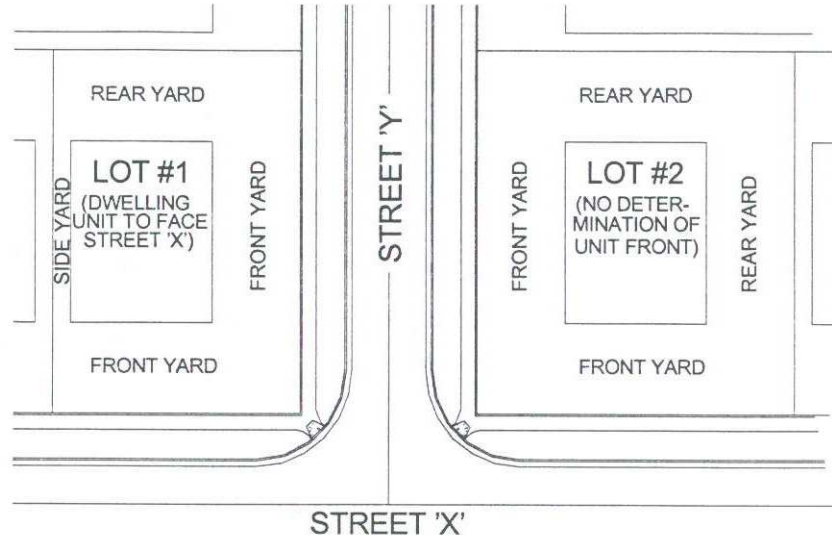

2. **Reduction in Lot Area Prohibited.** No lot, although it may consist of one or more adjacent lots of record, shall be reduced in area to the extent that yards, lot area, lot width, building area, or other requirements of this Ordinance are not maintained. Where a lot is affected by acquisition or condemnation for government purposes, the remaining lot may vary no more than 10 percent from these minimum standards and requirements. Where a greater than 10 percent variation occurs, it shall be considered a taking in entirety.
3. **Minimum Lot Area Above 100-Year Flood Level Required.** No lot served by public sanitary sewer shall be created or developed which does not have at least 5,000 square feet of lot area above the 100-year frequency flood level. No lot served by on-site septic systems shall be created or developed which does not have at least 20,000 square feet of lot area above the 100-year frequency flood level.
4. **Measurement of Lot Width.** Minimum lot width shall be measured at the building setback line. Curve or cul-de-sac lots shall be measured along the chord distance at the front setback between side property lines.

Article 4

Zoning Districts – Single Family Residential

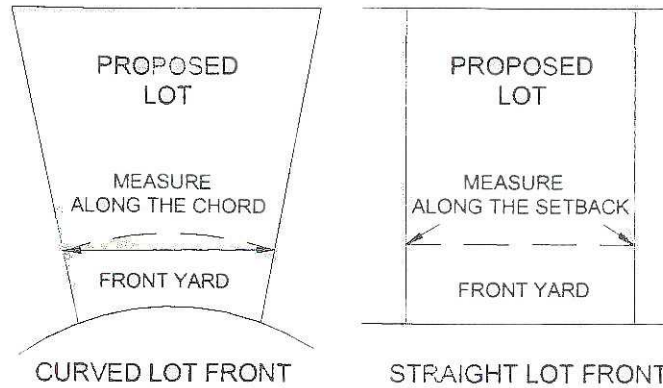

5. **Minimum Lot Frontage Required.** No building shall be erected on a lot, nor shall a lot be created, which does not abut at least one improved street for a distance of not less than 32 feet (see also Sec. 6.5 regarding nonconforming lots of record).

6. **Measurement of Lot Coverage.**

Lot coverage shall include all areas of the lot covered by buildings, structures (including accessory structures), patios, walkways, travelways, and parking areas, including gravel parking areas. Lot coverage does not include uncovered, semi-pervious decks or outdoor pools. The percent of lot coverage shall be determined by dividing the total covered area by the gross area of the lot.

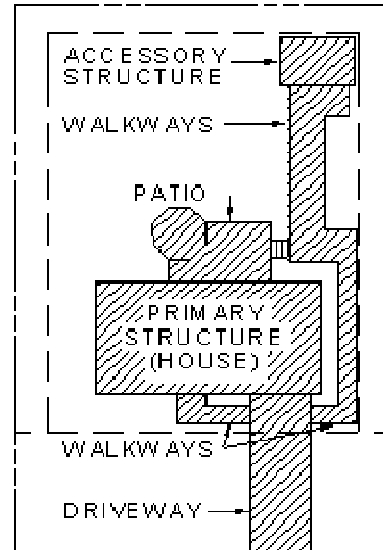

TYPICAL RESIDENTIAL
LOT COVERAGE

7. **Setbacks and Yards.**

a. **Lots Abutting Interstate or Other Highways.** Lots that abut an Interstate Highway, Parkway or other fully controlled access highways which allow no direct access shall have a minimum building setback line from the right-of-way of said highway of 25 feet. This building line shall be the same whether considered as front, side or rear setback.

b. **Distance Greater than Minimum Required.** Building setback lines as established by this Section may be greater than the minimums shown in the table in Sec. 4.4.5.B.; however, for purposes of establishing minimum lot width, this distance shall not exceed 100 feet.

Article 4

Zoning Districts – Single Family Residential

- c. **Variable Front Yard Setback.** A waiver from the strict enforcement of the front yard setback shown for a specific district may be granted by the Executive Director where the majority of existing development on the same block face is set back less than the required setback. In such case, the front yard setback may be the average setback line for that block face, or 10 feet, whichever is greater.

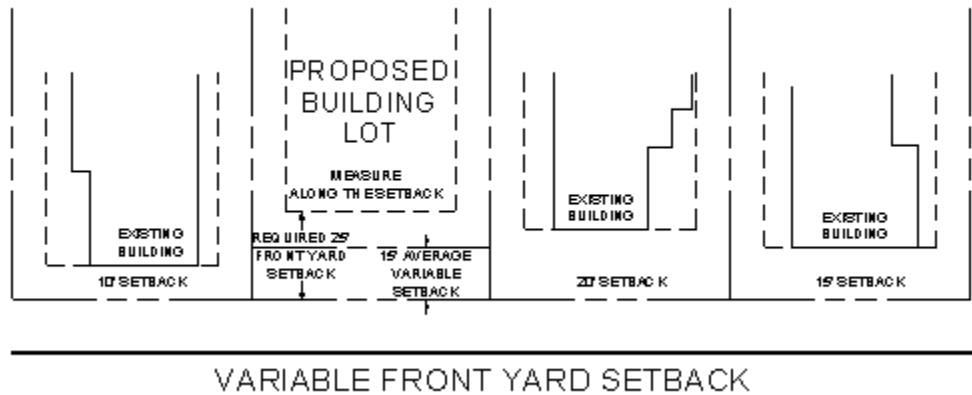

- 8. **Height Limit Exceptions.** The height limitations of this Ordinance shall not apply to church spires, belfries, cupolas and domes not intended for human occupancy; monuments; water towers; observation towers; flag poles; or chimneys.
- 9. **Parking Standard.**
 - a. No parking shall be located in excess of 25 percent of the front yard of the housing unit; parking is also allowed, however, in front of a garage or carport.
 - b. Circle drives shall be allowed provided they are: (1) located on lots with at least 125 feet of street frontage, (2) do not exceed the maximum lot coverage for the zoning district, and (3) are not considered in calculating the required off-street parking.
 - c. All parking areas, except in the R-E district, shall be paved with asphalt, concrete, brick pavers, or similar paving material.

D. Signs

- 1. Signage is allowed within Single Family Residential Districts on a limited basis and in accordance with the following table. No sign shall be externally or internally illuminated. All permitted signs shall also comply with all the applicable Sign Development Standards in Section 4.6.8.F.

Article 4

Zoning Districts – Single Family Residential

	R-E, RS, RR, MHS	MHP
Freestanding Signs Allowed?	Yes*	No
Maximum Number	1	N/A
Maximum Face Area	20 sf	N/A
Maximum Height	5 ft	N/A
Structure Type	Wall, Monument	N/A
Wall Signs Allowed?	Yes*	Yes
Maximum Face Area	12 sf	40 sf
Entrance Sign Allowed?	Yes	Yes

* In R-E, RS, RR and MHS Districts, signs are allowed for permitted conditional uses only.

2. Entrance Signs Standards.

- a. The content of an entrance sign shall be limited to the name of the subdivision only.
- b. No sign shall be internally illuminated.
- c. All entrance signs shall be constructed of durable materials.
- d. Landscaping is encouraged around entrance signs, provided the selected landscape materials will not grow to obscure sign face. No landscaping shall be erected to obstruct free and clear vision of an intersection and/or roadway.
- e. Structural Type and Size. Any entrance sign must be monument type and the maximum sign face shall be 60 sq. ft. total. Maximum height shall be 5 feet.
- f. Entrance signs may be allowed in public right-of-way only with written permission of the applicable jurisdiction.
- g. All permitted signs shall also comply with all the applicable Sign Development Standards in Section 4.6.8.F.

3. Personal Expression and Political Campaign Signs.

Temporary on-premise signs containing content of personal expression or political campaign shall not require a permit. These signs are allowed provided they otherwise comply with the following standards:

Article 4

Zoning Districts – Single Family Residential

- a. No sign shall be erected to obstruct free and clear vision of an intersection and/or traffic signals. No sign may be placed in or extended over a public right-of-way or utility easement without the express written consent of the controlling jurisdiction or utility.
- b. Signs shall be limited to a maximum of 16 s.f. in size (Campaign signs-32 square feet in unincorporated areas of Warren County).
- c. All permitted signs shall also comply with all the applicable Sign Development Standards in Section 4.6.8.F.

E. Accessory Structures. Accessory buildings, except as otherwise permitted by this Ordinance, shall require a building permit and shall be subject to the following regulations in all single family districts:

- 1. No accessory building or structure shall extend beyond the front of the principal structure, excluding fences 4 feet or less in height.
- 2. When a corner lot adjoins another lot in the rear which is used for residential purposes, no accessory building or structure shall extend beyond the front of the principal structure or be nearer to the side street than the depth of any required front yard for a dwelling along such side street, again excluding fences 4 feet or less in height.
- 3. An accessory building may not exceed the height of the principal structure.
- 4. The total area of all accessory buildings shall not exceed 50 percent of the ground floor area of the principal building.
- 5. No detached accessory building shall be located closer than 10 feet to any principal building, and may require greater separation when requested by the Fire Marshal.
- 6. An accessory building may be connected to the principal building by a breezeway or other similar structure but shall not project nearer the side lot line than the minimum side yard required for the main building. An accessory building located on a through lot shall conform to the required building setback line set forth for the District.
- 7. Accessory buildings/structures shall be permanently affixed to the ground and shall not include mobile home, bus, travel trailer, RV, trailer, cooler, vehicle or freight container.
- 8. Swimming Pools.
 - a. All swimming pools with a water depth of 3 feet or greater shall require a building permit.
 - b. A swimming pool as an accessory use to a residential structure shall be located no closer than 10 feet to the rear

Article 4

Zoning Districts – Single Family Residential

property line and no closer than 10 feet to a side property line. On a corner lot, the side yard setback shall be 25 feet. The setback shall be measured from the wall of the swimming pool to the nearest property line.

- c. The swimming pool area shall be enclosed by a fence or other suitable barrier with a minimum height of not less than 4 feet. Openings in the fence shall be small enough to prevent a child from entering the enclosure other than through the gate.
- 9. Fences. For the purpose of determining yard setback, the accessory structure setback shall not apply to fences. See 4.4.6 E (1) and (2) for front setback for fences.
- 10. No accessory structure that is not designated to breakaway on impact shall be permitted in the right-of-way. Such structures include, but are not limited to, rock or brick mailbox structures.

4.4.7 Residential Development Standards by Housing Type

A. Zero Lot Line

- 1. Development of a zero lot line dwelling shall occur only on a lot that has been specifically platted to accommodate such a use.
- 2. Side yards on lots with a zero lot line dwelling shall meet the following requirements.
 - a. One side yard must be a minimum of 10 feet.
 - b. The remaining side yard may range from 0 feet, up to a maximum of one foot, except for lots where minimum setbacks required from side streets or from adjoining lots in other zoning districts necessitate this remaining side yard to be a minimum of 5 feet. In no circumstance shall the separation between a zero lot line home and any dwelling on an adjoining lot be less than 10 feet.

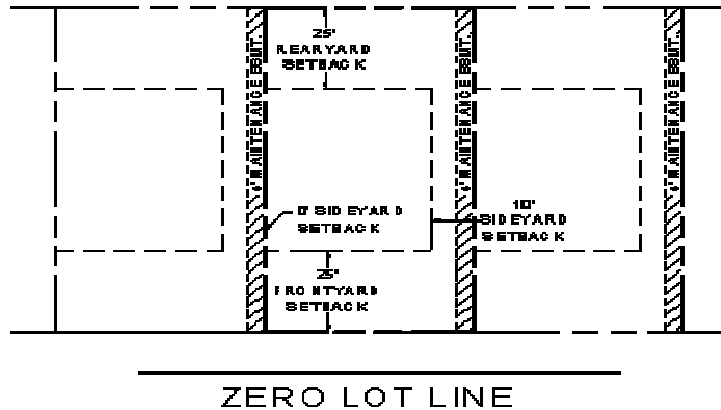

Article 4

Zoning Districts – Single Family Residential

- c. Any side yard abutting a street right-of-way must be a minimum of 25 feet.
 - d. Any side yard abutting a lot in a different zoning district must be a minimum of 5 feet or the width of the required side yard in the adjacent district, whichever is greater.
 - e. A maximum 2-foot eave overhang is allowed within these required side yards.
- 3. A perpetual easement with a minimum width of four feet shall be provided on the adjacent lot, for the maintenance of the wall of the dwelling with the zero lot line. This required easement shall be in favor of the lot on which a zero lot line is planned at or near the boundary to which this easement is adjacent. This required easement shall extend along the entire length of the side boundary to which the easement is adjacent.
 - 4. No doors, windows, air conditioning units, utility meters, electric panel boxes or openings of any kind shall be allowed on the wall of a dwelling or accessory building that lies on a zero lot line, with the exception of translucent windows approved by the Building Inspector. For the purposes of this paragraph alone:
 - a. any portion of an exterior wall which lies less than 3 feet from and substantially parallel to a side boundary shall be considered on the zero lot line; and
 - b. any portion of an exterior wall which lies less than 3 feet from and substantially perpendicular to a side boundary shall be considered on the zero lot line.
 - 5. The roof of each unit must be designed to prevent stormwater runoff from draining onto the adjacent lot.
 - 6. Required easements shall be shown on the final plat. If required easements are not shown on the final plat of lots for zero lot line homes, then such easements shall be created by means of a replat or other separate recorded legal instrument before permits for building are granted.
 - 7. In no case shall the owner of any zero lot line dwelling be granted an easement on the adjoining property for the use or enjoyment of any portion of that property.

B. Manufactured Housing Subdivision

Manufactured housing subdivisions may be developed in accordance with the Use Table in Section 5.1 and the following requirements.

- 1. **Minimum Land Area.** Each manufactured housing subdivision shall contain a minimum of 5 contiguous acres of land and a minimum of 10 lots.

Article 4

Zoning Districts – Single Family Residential

Development of a smaller tract of land adjacent to an existing manufactured housing subdivision may be permitted, provided that:

- a. Proposed development conforms to and extends the original manufactured housing subdivision; and
- b. Proposed development otherwise conforms to all of the requirements of this Ordinance.

2. Street Access and Design.

- a. The manufactured housing subdivision shall be located with direct access to a public street and shall have a minimum of 50 feet of frontage.
- b. Entrances and exits for the manufactured housing subdivisions shall conform to the Subdivision Regulations.
- c. No entrance or exit for a manufactured housing subdivision shall have an intersection angle less than 80 degrees and the radii of curbs and pavements at intersections shall not be less than 35 feet.
- d. The individual lots within the manufactured housing subdivision shall not be located with direct access to the public streets except those streets within the subdivision approved under this section.
- e. Drainage. Each manufactured housing subdivision shall conform to the Stormwater Management Program regulations.

3. Development Standards.

- a. Each manufactured housing unit in the subdivision must be set on a permanent foundation with permanent masonry skirting.
- b. No units less than 16 feet in width shall be permitted.
- c. All roofs shall have a minimum 3:12 pitch.
- d. Exterior siding shall be constructed of vinyl, wood or masonry.
- e. All drives and parking areas shall be paved.

C. Mobile Home Park

- 1. **General Property Development Standards.** Each area proposed to be zoned MHP District shall meet the standards set forth in the Subdivision Regulations, prior to issuance of building permits.

Article 4

Zoning Districts – Single Family Residential

2. Minimum Area of Park.

- a. Each mobile home park shall contain a minimum of 5 contiguous acres of land and 25 mobile home spaces.
- b. Development of a smaller tract of land adjacent to an existing mobile home park may be permitted, provided that:
 - (1) The proposed development conforms to and extends the original mobile home park;
 - (2) The proposed development site is properly zoned;
 - (3) The proposed development otherwise conforms to all of the standards and requirements of this Ordinance.

3. Space Standards. Minimum space standards for the mobile home park are as follows:

Space Standard	Requirement
Space Size , minimum sq. ft.	5,000
Front Setback , minimum from street pavement	20 feet
Separation from other housing units, buildings or accessory structures	15 feet

4. Open Space.

- a. In each mobile home park there shall be provided one or more open space areas which shall be easily accessible to all park residents, centrally located, and free of traffic hazards. Pedestrian travelways (sidewalks, trails) are encouraged.
- b. The size of such open space area shall be equal to a minimum of 400 square feet for each housing unit. No open space area shall contain less than 10,000 square feet. Retention areas may not be considered open space or counted towards this requirement.

5. Setbacks, Buffer Strips and Screening.

- a. All spaces and permitted accessory uses and structures shall be located at least 50 feet from any park property boundary line abutting upon a public street and at least 25 feet from other park property boundary lines.
- b. There shall be a minimum distance of 20 feet between the housing unit and the edge of the abutting internal park street.

Article 4

Zoning Districts – Single Family Residential

- c. All mobile home parks shall be provided with visual perimeter screening in accordance with the Commercial Development landscaping provisions in Section 4.6.8.D.

6. **Minimum frontage.** The mobile home park shall be located with direct access to an arterial or collector street as designated by the Kentucky Transportation Cabinet or the City of Bowling Green and shall have a minimum of 50 feet of frontage.

7. **Internal Park Streets.** All unit spaces and permitted accessory uses and structures shall front on an internal park street only. All internal streets shall meet the following minimum requirements:
 - a. All internal streets shall be 18 feet in width with no on-street parking or 24 feet with on-street parking.
 - b. Dead-end streets shall be limited in length to 600 feet and shall be provided at the closed end with a cul-de-sac having a minimum diameter of 80 feet.
 - c. All mobile home parks shall be equipped with street lighting units which shall comply with the minimum recommended standards contained in the American Association of State Highway and Transportation Officials (AASHTO) publication entitled, "Information Guide for Roadway Lighting."
 - d. All streets within the mobile home park shall conform to the street construction and design standards of the subdivision regulations of Warren County except as herein modified.

8. **Off-Street Parking.** Off-street parking areas or on-street parking lanes shall be provided for the use of park occupants and guests. Such areas shall be accessible by motor vehicles from the internal park street and two (2) parking spaces per housing space is required.

9. **Design Standards.**
 - a. All housing unit spaces shall be designed so that the unit can be moved on or off the site without moving any other unit.
 - b. All units must meet the HUD Code for manufactured housing or be affixed with a Commonwealth of Kentucky "B" Seal.
 - c. All units must be in good repair at the time of their placement, and shall be maintained in good repair thereafter.
 - d. Each unit shall be placed on a permanent foundation, and skirted to enclose the area below the unit.

10. **Mobile Home Stands.** The area of the mobile home stand shall be improved to provide adequate support for the placement and tiedown of the housing unit, thereby securing the superstructure against uplift, sliding, rotation, and overturning. The mobile home stand shall not

Article 4

Zoning Districts – Single Family Residential

heave, shift or settle unevenly under the weight of the mobile home due to frost action, inadequate drainage, vibration or other forces acting on the structure.

11. **Anchors and Tiedowns.** The mobile home stand shall be provided with permanent anchors and tiedowns which shall secure the stability of the housing unit. Each housing unit shall be secured in such a manner as to prevent the uplift, sliding, rotation, or over turning of the superstructure.
12. **Water Supply.** All mobile home parks shall be served by a public water system that can provide 600 GPM at 20 PSI residual pressure and meet the applicable fire hydrant ordinance.
13. **Sewage Disposal.** All mobile home parks shall be connected to the public sewer system. Individual septic systems may not be used.
14. **Entrance Signs.** Signs intended to be seen outside property boundary lines shall meet the following standards:
 - a. One non-illuminated identity monument sign at each entrance to the mobile home park not to exceed 60 square feet per side shall be permitted. All permitted signs shall also comply with all the applicable Sign Development Standards in Section 4.6.8.F.
 - b. No sign shall project beyond a setback line, or obstruct in any way a driver's vision of the road.
 - c. One unlighted sign advertising the sale or rental of a housing unit or space shall be placed only on that space of the unit or space which is to be rented or sold.
 - d. One unlighted sign advertising the sale or rental of any unit or space located within the mobile home park may be located at the entrance of such park provided said sign shall not be over 16 square feet in area.
15. **Other Development Standards**
 - a. **Responsibilities of Park Management.** The mobile home park owner shall be responsible for operating the park in compliance with this Zoning Ordinance, meeting all standards and requirements herein, and shall be responsible for and provide adequate supervision to maintain the park, its facilities and equipment in good repair and in a clean and sanitary condition.
 - b. **Housing Unit Placement.** The mobile home park owner shall supervise and be responsible for the placement of each housing unit on its stand in accordance with requirements of this Section, including securing the stability of the housing unit and installing all utility connections.

Article 4

Zoning Districts – Single Family Residential

- c. **Space Numbering.** The mobile home park owner shall number each space and shall submit a plan of the park with each space numbered thereon to the Warren County Sheriff's Office, City-County Planning Commission, ambulance service, the fire department within which the mobile home park is located, the Bowling Green Police Department if located within the corporate limits of Bowling Green, and the property valuation administrator. If the numbering of the spaces changes, the mobile home park owner shall submit changes to the departments and agencies set forth above.
16. **Existing Nonconforming Parks.** For existing parks which are located in any zoning district other than Mobile Home Park, any plans to extend or to expand onto contiguous property, shall necessitate a zoning change in accordance with Sec. 3.10 Map Amendment (Rezoning), and the filing of a development plan on the entire property. The development plan shall indicate existing and proposed layouts, sizes and densities. All proposed expansions shall meet all current standards and requirement of this Zoning Ordinance.

SEC. 4.5 MULTI-FAMILY RESIDENTIAL DISTRICTS

4.5.1 Two-Family Residential District (RM-2)

- A. Purpose and Intent.** The Two-Family Residential District is intended to provide housing opportunities for two-family residential development, including, twinhomes and duplexes. This district shall be served by public sanitary sewer.
- B. Permitted Residential Unit Types.** The following residential unit types shall be permitted in this District:
 - 1. Twinhomes;
 - 2. Duplexes; and
 - 3. Residential unit types permitted in RS-1B district (utilizing RS-1B property development standards).

4.5.2 Townhouse and Multi-Family Residential District (RM-3)

- A. Purpose and Intent.** The Townhouse/Multi-Family Residential District is intended to provide housing opportunities for townhouse and multi-family development of up to 8 units in a single building. This district shall be served by public sanitary sewer.
- B. Permitted Residential Unit Types.** The following residential unit types shall be permitted in this District:
 - 1. Townhomes containing 3 to 8 units per building;
 - 2. Condominiums containing 3 to 8 units per building;
 - 3. Apartments containing 3 to 8 units per building;
 - 4. Two-family residential unit types permitted in RM-2 district (utilizing RM-2 property development standards for twinhome development only); and
 - 5. Residential unit types permitted in RS-1C district (utilizing RS-1C property development standards).

4.5.3 Multi-family Residential District (RM-4)

- A. Purpose and Intent.** The Multifamily Residential District is intended to provide housing opportunities for townhouse and apartment development with greater than eight (8) units per building. This district shall be served by public sanitary sewer.
- B. Permitted Residential Unit Types.** The following residential unit types shall be permitted in this District:
 - 1. Condominiums containing greater than 8 units per building;
 - 2. Apartments containing greater than 8 units per building;
 - 3. Residential unit types permitted in the RM-3 district;
 - 4. Residential unit types permitted in RM-2 district (utilizing RM-2 property development standards for twinhome development only); and,

Article 4

Zoning Districts – Multi-Family Residential

5. Residential unit types permitted in RS-1C district (utilizing RS-1D property development standards).

4.5.4 General Residential Development Standards

- A. Uses.** Uses permitted in each District are shown in the Use Table in Sec. 5.1. This table employs broad use categories containing a variety of similar uses. The use categories are described in Sec. 5.2, Use Categories, and Appendix B lists examples of uses, showing which use categories they fall into. Additional standards for specific uses, if any, can be found in each category. Properties which have recorded binding elements limiting their use to single family residential shall be limited to one-family occupancy per residential unit.
- B. Property Development Standards.** Development in each Multi-family Residential District shall comply with the general residential development standards in the following tables:

	RM-2 Duplex	RM-2 Twinhome	RM-3	RM-4
Lot Area (min sf) ** Public Sewer	11,000	5,500 / unit	8,000 sf plus 2,000 sf for each unit >1	5,000 sf plus 1,500 sf for each unit >1
Septic System	N/A	N/A	N/A	N/A
Lot Width (min at bldg line)	75feet	37.5feet/ unit	40 feet	40 feet
Lot Frontage (min) Public Street Cul-de-Sac (bulb only)	50 feet 40 feet	25 feet/ unit 20 feet/ unit	50 feet 40 feet	50 feet 40 feet
Lot Coverage (max)	75%	75%	75%	75%
Setbacks (min) Front Yard Side Yard Rear Yard Accessory Structure	25 feet 7.5 feet 10 feet 5 feet	25 feet 7.5 feet 10 feet 5 feet	25 feet* 10 feet 10 feet 5 feet	25 feet* 10 feet 10 feet 5 feet
Height (max)	42 feet	42 feet	42 feet	4 stories above grade
Fire Protection Required? (Sec. 6.3)	Yes 600 GPM	Yes 600 GPM	Yes 600 GPM	Yes 600 GPM
Off-Street Parking (spaces required)	4 total	2 spaces per unit	Bed Sp 1 1.5 2 2.5 3 3.5 4 4.0	Bed Sp 1 1.5 2 2.5 3 3.5 4 4.0

*See Sec. 4.5.5.B.3 for setback provisions for townhomes.

** For the RM-3 and RM-4 districts, there are also maximum density standards (units/acres) for apartments (see 4.5.5.C)

Article 4

Zoning Districts – Multi-Family Residential

C. Other Standards

1. **Corner lots.** Corner lots shall be required to provide a front yard along any lot line abutting a street. Unless the plat is expressly marked as to the street the dwelling will front on, a rear yard shall be substituted for any side yard not abutting a street.

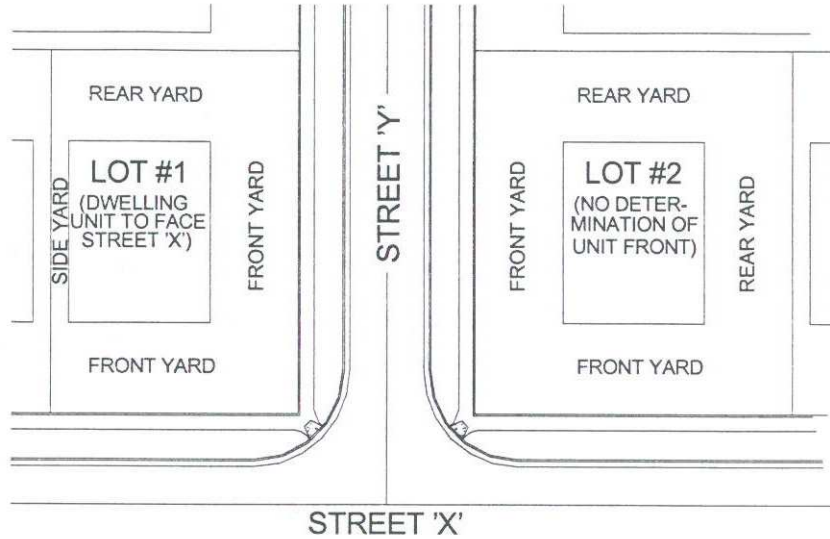

2. **Reduction in Lot Area Prohibited.** No lot, although it may consist of one or more adjacent lots of record, shall be reduced in area to the extent that yards, lot area, lot width, building area, or other requirements of this Ordinance are not maintained. Where a lot is affected by acquisition or condemnation for government purposes, the remaining lot may vary no more than 10 percent from these minimum standards and requirements. Where a greater than 10 percent variation occurs, it shall be considered a taking in its entirety.
3. **Minimum Lot Area Above 100-Year Flood Level Required.** No lot served by public sanitary sewer shall be created or developed which does not have at least 5,000 square feet of lot area above the 100-year frequency flood level. No lot served by on-site septic systems shall be created or developed which does not have at least 20,000 square feet of lot area above the 100-year frequency flood level.
4. **Measurement of Lot Width.** Minimum lot width shall be measured at the building setback line. Curve or cul-de-sac lots shall be measured along the chord distance at the front setback between side property lines.

Article 4

Zoning Districts – Multi-Family Residential

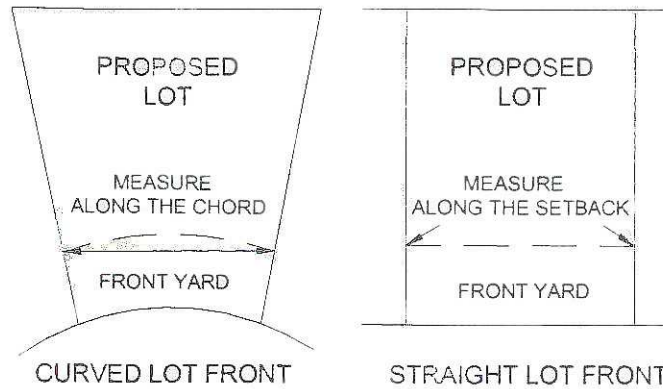

5. **Minimum Lot Frontage Required.** No building shall be erected on a lot, nor shall a lot be created, which does not abut at least one improved street for a distance of not less than 32 feet (see also Sec. 6.4 regarding nonconforming lots of record).

6. **Measurement of Lot Coverage.** Lot coverage shall include all areas of the lot covered by buildings, structures (including accessory structures), patios, walkways, travelways, and parking areas, including gravel parking areas. Lot coverage does not include uncovered, semi-pervious decks or outdoor pools. The percent of lot coverage shall be determined by dividing the total covered area by the gross area of the lot.

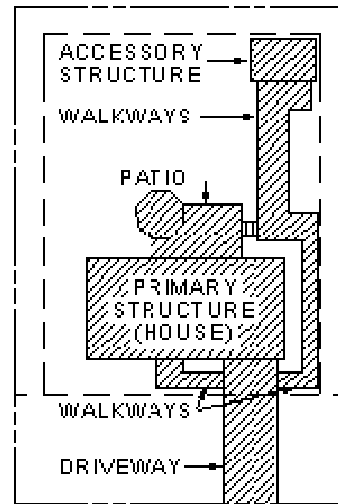

TYPICAL RESIDENTIAL LOT COVERAGE

7. **Setbacks and Yards.**

a. **Lots Abutting Interstate or Other Highways.**

Lots that abut an Interstate Highway, Parkway or other fully controlled access highways which allow no direct access shall have a minimum building setback line from the right-of-way of said highway of 25 feet. This building line shall be the same whether considered as front, side or rear setback.

b. **Distance Greater than Minimum Required.** Building setback lines as established by this Section may be greater than the minimums shown in the table in Sec. 4.5.4.B; however, for purposes of establishing minimum lot width, this distance shall not exceed 100 feet.

Article 4

Zoning Districts – Multi-Family Residential

- c. **Variable Front Yard Setback.** A waiver from the strict enforcement of the front yard setback shown for a specific district may be granted by the Executive Director where the majority of existing development on the same block face is set back less than the required setback. In such case, the front yard setback may be the average setback line for that block face, or 10 feet, whichever is greater.

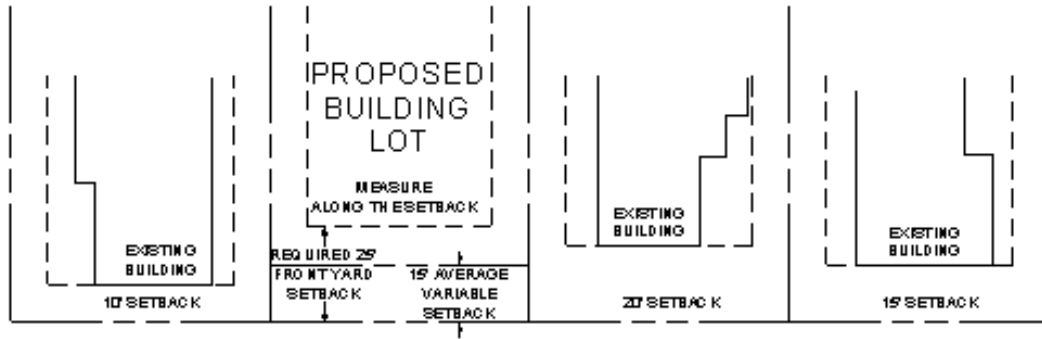

VARIABLE FRONT YARD SETBACK

- 8. **Height Limit Exceptions.** The height limitations of this Ordinance shall not apply to church spires, belfries, cupolas and domes not intended for human occupancy; monuments; water towers; observation towers; flag poles; or chimneys.
- 9. **Parking Standard.** All parking areas shall be paved with asphalt, concrete, brick pavers, or similar material. For any single family residential use in RM-2, RM-3, or RM-4, no parking shall be located in excess of 25 percent of the front yard of the housing unit; parking is also allowed, however, in front of a carport or garage. Required parking shall be provided according to the Development Standards table found in this section and the "Off-Street Parking and Loading" in Section 4.6.8.E.2, 4.6.8.E.3, 4.6.8.E.4, 4.6.8.E.5, and 4.6.8.E.6.
- D. **Landscaping.** All multi-family residential development shall comply with the minimum landscaping standards as set forth in the Commercial Development Standards in Section 4.6.8.D.
- E. **Signs**
 - 1. Signage is allowed within Multi-Family Residential Districts on a limited basis and in accordance with the following table. No sign shall be externally or internally illuminated. All permitted signs shall also comply with all the applicable Sign Development Standards in Section 4.6.8.F.

Article 4

Zoning Districts – Multi-Family Residential

	RM-2, RM-3, and RM-4
Freestanding Signs Allowed?	No
Maximum Number	N/A
Maximum Face Area	N/A
Maximum Height	N/A
Structure Type	N/A
Wall Signs Allowed?	Yes*
Maximum Face Area	40 sf
Entrance Sign Allowed?	Yes

* In RM-2, RM-3, and RM-4 districts, signs are allowed for properly permitted conditional uses only.

2. Entrance Signs Standards.

- a. The content of an entrance sign shall be limited to the name of the subdivision or residential complex only.
- b. No sign shall be internally illuminated.
- c. All entrance signs shall be constructed of durable materials.
- d. Landscaping is encouraged around entrance signs, provided the selected landscape materials will not grow to obscure sign face. No landscaping shall be erected to obstruct free and clear vision of an intersection and/or roadway.
- e. Structural Type and Size. Any entrance sign must be monument type and the maximum sign face shall be 60 sq. ft. total. Maximum height shall be 5 feet.
- f. Entrance signs may be allowed in public right-of-way only with written permission of the applicable jurisdiction.
- g. All permitted signs shall also comply with all the applicable Sign Development Standards in Section 4.6.8.F.

3. Personal Expression and Political Campaign Signs.

Temporary on-premise signs containing content of personal expression or political campaign shall not require a permit. These signs are allowed provided they otherwise comply with the following standards:

- a. No sign shall be erected to obstruct free and clear vision of an intersection and/or traffic signals. No sign may be placed in or extended over a public right-of-way or utility easement without the express written consent of the controlling jurisdiction or utility.

Article 4

Zoning Districts – Multi-Family Residential

- b. Signs shall be limited to a maximum of 16 s.f. in size (Campaign signs-32 square feet in unincorporated areas of Warren County).
- c. All permitted signs shall also comply with all the applicable Sign Development Standards in Section 4.6.8.F.

F. Accessory Structures. Accessory buildings, except as otherwise permitted by this Ordinance, shall require a building permit and shall be subject to the following regulations in all multi-family districts.

- 1. No accessory building or structure shall extend beyond the front of the principal structure, excluding fences 4 feet or less in height.
- 2. When a corner lot adjoins another lot in the rear which is used for residential purposes, no accessory building or structure shall extend beyond the front of the principal structure or be nearer to the side street than the depth of any required front yard for a dwelling along such side street, again excluding fences 4 feet or less in height.
- 3. An accessory building may not exceed the height of the principal structure or 42 feet, whichever is less.
- 4. Accessory buildings shall not exceed 50 percent of the ground floor area of the principal building.
- 5. No detached accessory building shall be located closer than 10 feet to any principal building, and may require greater separation when requested by the Fire Marshal.
- 6. Any detached accessory structure having a floor area of 750 s.f. or greater must meet the principal structure setback requirements.
- 7. An accessory building may be connected to the principal building by a breezeway or other similar structure but shall not be considered as an attached accessory building, carport, or similar structure. Said breezeway shall not project nearer the side lot line than the minimum side yard required for the main building. An accessory building located on a through lot shall conform to the required building setback line set forth for the District.
- 8. Accessory buildings/structures shall be permanently affixed to the ground and shall not include mobile home, bus, travel trailer, RV, trailer, cooler, vehicle or freight container.
- 9. Swimming Pools.
 - a. All swimming pools with a water depth of 3 feet or greater shall require a building permit.
 - b. A swimming pool as an accessory use to a residential structure shall be located no closer than 10 feet to the rear property line and no closer than 10 feet to a side property

Article 4

Zoning Districts – Multi-Family Residential

line. On a corner lot, the side yard setback shall be 25 feet. The setback shall be measured from the wall of the swimming pool to the nearest property line.

- c. The swimming pool area shall be enclosed by a fence or other suitable barrier with a minimum height of not less than 4 feet. Openings in the fence shall be small enough to prevent a child from entering the enclosure other than through the gate.
10. No accessory structure that is not designated to breakaway on impact shall be permitted in the right-of-way. Such structures include, but are not limited to rock or brick mailbox structures.

4.5.5 Residential Development Standards by Housing Type

- A. **Twinhome.** Only one twinhome dwelling unit shall be allowed on a single lot.

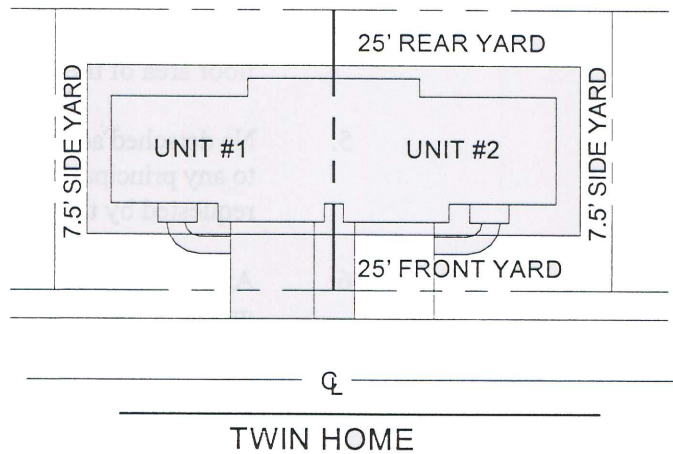

- B. **Townhomes.**
 - 1. **Platted Lot Required.** Each unit shall be developed on a separately platted and recorded lot.
 - 2. **Lot Size.**
 - a. Minimum lot size for each platted lot shall be 1,600 square feet, exclusive of floodplain.
 - b. Minimum lot width shall be 18 feet for an interior unit and 28 feet for an end unit.
 - 3. **Setbacks.**
 - a. **Front Yard.** Minimum 30 feet with no garage on a public street, 15 feet with no garage on a private street, 18 feet with a garage on a public or private street, 15 feet with designated off-site or private parking.

Article 4

Zoning Districts – Multi-Family Residential

- b. Side Yards. End units shall maintain a minimum 10-foot side yard setback. Interior units are not required to provide setbacks.
- c. Rear Yard. Minimum 25 feet.



30' SETBACK WITH FRONT PARKING AND NO GARAGE*
18' SETBACK WITH SINGLE WIDE DRIVE AND GARAGE
15' SETBACK OFF LOT OR REAR PARKING

*MINIMUM SPACING BETWEEN PARKING SPACE AND UNIT WITH NO GARAGE SHALL BE 10 FEET WITH FRONT PARKING

4. Off-Street Parking and Drives.

- a. Each townhouse shall have at least 2 paved off-street parking spaces located on the lot belonging to each townhouse, or within 100 feet of the unit.
- b. Parking spaces that do not have a private access from a public way shall have access via a private drive for which perpetual maintenance shall be provided. Perpetual maintenance shall be provided through an agreement or covenant which is properly recorded and which runs with the land. Such agreement shall receive the prior approval of the Planning Commission staff and shall be recorded in the office of the County Court Clerk of Warren County, Kentucky.

Article 4

Zoning Districts – Multi-Family Residential

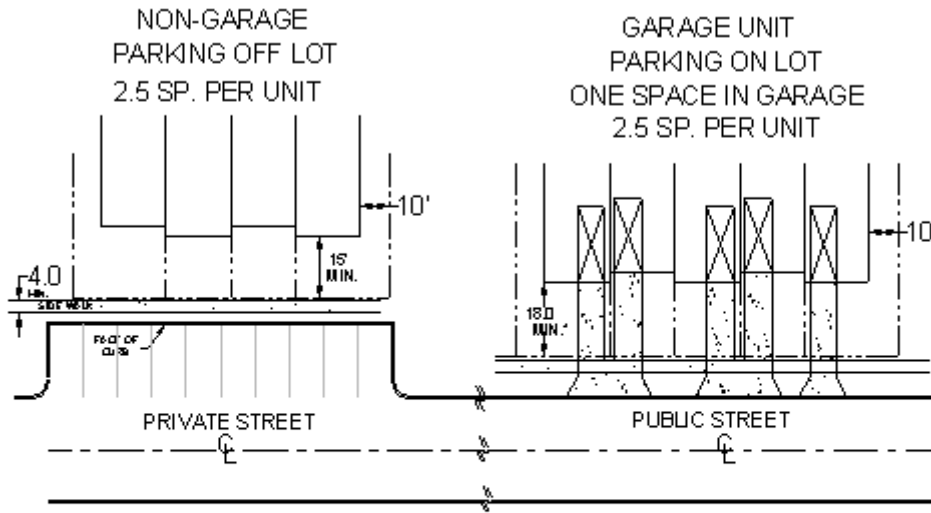

EXAMPLE USING 18' WIDE TOWNHOUSE
SHOWING OFF LOT VS. ON LOT PARKING
AND FRONT BUILDING SETBACKS AND SIDE YARD

*FOR A DRIVEWAY PARKING SPACE TO BE COUNTED
TOWARDS THE PARKING REQUIREMENTS IT SHALL
BE A MINIMUM OF 18' IN LENGTH

5. **Party Walls and Roofs.**

- a. Party walls shall be constructed in conformance with the Kentucky Building Code provisions.
- b. Party walls shall be perpetually maintained, repaired and replaced through a party wall agreement with provisions for arbitration. Such agreement shall receive the prior approval of the Planning Commission Staff and shall be recorded in the office of the County Court Clerk of Warren County, Kentucky.
- c. All townhomes sharing a common wall shall have a minimum 24-inch offset in the front and rear building lines.
- d. Each townhome unit shall have an independent roof.

6. **Recreation Space.** Each townhome development with 10 units or more shall maintain a minimum of 3,000 square feet of common recreational space to serve the townhome development. For developments of greater than 10 units, an additional 100 square feet of recreational space shall be required for each additional unit beyond the 10th unit. Retention areas shall not be considered recreation space for the purposes of this paragraph. Such common space shall be provided for and maintained by a property owners association.

7. **Subdivision Regulation Coordination.** Any development approved under this section shall be considered a major plat.

Article 4

Zoning Districts – Multi-Family Residential

- C. Apartments.** Overall density of an apartment project shall not exceed 15 units per gross acre for RM-3, and 26 units per gross acre for RM-4.
- D. Condominium (Horizontal Property)**
1. The intent and application of this Ordinance is to implement and reaffirm the Horizontal Property Law of Kentucky (KRS 381).
 2. A master deed or lease or floor plans meeting the standards set forth in KRS 381 shall not be filed in the office of the Warren County Clerk without having first been reviewed and approved by the Planning Commission.
 3. The maximum permitted overall densities and floor area ratios and the minimum outdoor area, living space, and recreation area ratios shall be controlled by the zoning district classification in which the project is located.
 4. The establishment, expansion or diminution of a horizontal property regime shall be subject to review and approval by the Planning Commission in the same manner as approval of a detailed development plan.

SEC. 4.6 COMMERCIAL AND OFFICE/PROFESSIONAL DISTRICTS

4.6.1 Neighborhood Business District (NB)

The Neighborhood Business District is intended to provide opportunities for neighborhood-scale commercial development that provides daily services and goods to the immediately surrounding area.

4.6.2 General Business District (GB)

The General Business District is intended to provide opportunities for commercial development that serves the entire community or region.

4.6.3 Central Business District (CB)

The Central Business District is intended to provide for the continued vitality of downtown Bowling Green and the maintenance and re-use of existing historic structures. This district shall be served by public sanitary sewer.

4.6.4 Highway Business District (HB)

The Highway Business District is intended for the development of businesses that require a high volume of vehicular traffic due to the nature of the products or services offered by the business. This District is appropriate for parcels having frontage on collector or arterial streets, or within one-half mile of an interstate or Kentucky Toll Road interchange.

4.6.5 Office and Professional - Residential District (OP-R)

This district is established with the purpose and intent of providing space for professional offices in appropriate locations to accommodate the needs of the community. The district is intended to serve as the transition between commercial areas and adjacent residential development.

4.6.6 Office and Professional - Commercial District (OP-C)

This district is established with the purpose and intent of providing space for professional offices in appropriate locations to accommodate the needs of the community. The district is intended to serve large-scale offices in commercial or industrial areas.

4.6.7 Public District (P)

The Public District is intended to provide for public and quasi-public development, including open lands such as parks, and developed uses including government building, hospitals, and schools. Use of the Public District is limited to agencies and entities receiving or utilizing public funding.

4.6.8 General Commercial Development Standards

- A. Uses.** Uses permitted in each District are shown in the Use Table in Sec. 5.1. This table employs broad use categories containing a variety of similar uses. The use categories are described in Sec. 5.2, Use Categories, and Appendix B lists examples of uses, showing which use categories they fall into. Additional standards for specific uses, if any, can be found in each category.
- B. Property Development Standards.**
- Development in each District shall comply with the general commercial development standards in the following table:

	NB	GB	CB	HB	OP-R	OP-C	P
Lot Area, min. sq. ft. Public Sewer Septic System *	5,000 130,680	5,000 130,680	0 N/A	5,000 130,680	5,000 130,680	5,000 130,680	5,000 130,680
Lot Width, min. ft. at Bldg. Line	50	50	0	50	50	50	50
Lot Frontage, min. ft.	50	50	0	50	50	50	50
Lot Coverage, max.	75%	75%	100%	90%	50%	75%	90%
Setbacks, min. ft. Front Yard Side Yard Rear Yard Accessory Structure	25 0 0 0	25 0 0 0	0 0 0 0	25 0 0 0	25 10 25 0	25 0 0 0	25 0 0 0
Height, max.	42 feet	3 stories	4 stories	None	42 feet	6 stories	None
Building Size, max. s.f.	4,000	N/A*	N/A*	N/A*	4,000	N/A	N/A
Parking	See specific use chart in 4.6.8.E for parking requirements.						
Fire protection required?	600 GPM	600 GPM	600 GPM	600 GPM	600 GPM	600 GPM	600 GPM
Landscaping required?	See Section 4.6.8.D for landscaping requirements.						
Residential uses allowed?	Yes	Yes	Yes	Yes	Yes	Yes	Yes
What standard?	RS-1D or Accessory Use	RM-3 or RS-1D or Accessory Use	Accessory Use	Accessory Use	RS-1D	RM-3 or RS-1D	Accessory Use

* Commercial uses with on-site septic systems are limited to a 6,000 s.f. building. This maximum building size may be increased to 10,000 s.f. if the lot area is a minimum of 5 acres. (see Article 1.12.2.A.3.)

2. **Minimum Lot Area Above 100-Year Flood Level Required.** No lot served by public sanitary sewer shall be created or developed which does not have at least 5,000 square feet of lot area above the 100-year frequency flood level. No lot served by on-site septic systems shall be created or developed which does not have at least 20,000 square feet of lot area above the 100-year frequency flood level.
3. **Variable Front Yard Setback.** A waiver from the strict enforcement of the front yard setback shown for a specific district may be granted by the Executive Director where the majority of existing development on the same block face is set back less than the required setback. In such case, the front yard setback may be the average setback line for that block face, or 10 feet, whichever is greater.

C. Additional Setback Adjacent to Residential District.

Development in any business or industrial district adjacent to the boundary of a residential zoning district shall require the following setbacks:

1. **Commercial District Adjacent to Residential District (OP-C, HB and GB).**

For existing structures, the yard that abuts the residential district boundary shall have the same dimension as the abutting residential district. For all new structures, any yard abutting a residential district shall have a minimum 20-foot side and a 40-foot rear yard setback.

2. **Commercial District Adjacent to Residential District (OP-R, NB, P and CB).** A rear yard abutting a residential district shall have a minimum 25-foot rear yard setback, and a side yard abutting a residential district shall have a minimum 10-foot side yard setback.

D. Landscaping. All commercial development shall comply with the minimum landscaping standards as follows:

3. **Applicability**

- a. No new site development, building, structure, or vehicle use area (VUA) shall hereafter be constructed or used unless landscaping is provided as required by the provisions of this Section, regardless of the need for a building permit.
- b. No building, structure or VUA shall be expanded or moved unless the minimum landscaping is provided as required by the provisions of this Section.
- c. No building, structure, or VUA shall be reconstructed unless the minimum landscaping is provided as required by the provisions of this Section.
- d. No use shall be changed to another use for which this Ordinance requires additional parking over that which was required for the previous use, unless the VUA perimeter and interior VUA landscaping as required by this Section is provided for such additional parking, where the previous use

Article 4

Zoning Districts – Commercial and Office/Professional

had no required parking, perimeter and interior VUA landscaping shall be provided for all new VUA serving the new use. Interior landscaping shall not be required where only the use of the property is changed and no new construction or reconstruction of any VUA is proposed.

- e. No use of an existing building, structure, or VUA shall be commenced subsequent to a change in zoning unless all landscaping as required by this Section is provided.
 - f. The buffering requirements of this Section shall not apply to the construction of agricultural buildings or for the development of single family detached residential units adjacent to existing single family residential.
 - g. All uses in the Central Business (CB) District, except parking lots and vehicle use areas, shall be exempt from the landscaping provisions of this Ordinance.
4. **Buffers between incompatible land uses.** Land uses that are determined to be incompatible by the City-County Landscape Architect or the Executive Director of the Planning Commission shall be buffered at the following rate:
- a. Three deciduous shade trees and six evergreen trees per each 100 linear feet of buffer, or two deciduous shade trees, three evergreen trees and twelve shrubs per 100 linear feet of buffer.
 - b. Up to one-half of the deciduous shade trees and evergreens may be substituted with ornamental trees. The substitution rate shall be two ornamental trees for each shade or evergreen tree.
 - c. The required buffer shall be located along the property boundary adjacent to the incompatible land use.
 - d. All buffers located between incompatible land uses must be an average of ten feet in width with the minimum dimension being five feet.
5. **Screening of Vehicle Use Areas (VUA).**
- a. When a VUA is located adjacent to any property line other than a public right-of-way, the screen shall be planted at the following rate:
 - (1) Three deciduous shade trees and two evergreen trees per 100 linear feet of screening, for the area where the VUA is adjacent to, and within 100 feet of a common property line, or two deciduous shade trees, 20 shrubs per 100 linear feet of screening.

Article 4

Zoning Districts – Commercial and Office/Professional

- (2) Up to one-half of the deciduous shade trees and evergreens may be substituted with ornamental trees. The substitution rate shall be two ornamental trees for each shade or evergreen tree.
 - (3) All screening between a VUA and a common property line must be an average of ten (10) feet in width with the minimum dimension being five (5) feet.
 - (4) When a VUA is located adjacent to any public right-of-way, the screen shall contain:
 - i. A minimum of 70 percent of the distance where a VUA is adjacent to a right-of-way or common property line shall be screened with shrubs to be maintained at a minimum of 24 inches and a maximum of 42 inches in height, with one-half of the shrubs used for this being of an evergreen species.
 - ii. Two deciduous shade trees per 100 linear feet of screen. Shade trees may be substituted with ornamental trees at the rate of two ornamental trees per shade tree.
 - iii. All screens between a VUA and right-of-way must be an average of ten feet in width with the minimum dimension being five feet.
6. **Interior VUA Landscaping.** Any open VUA (excluding loading, unloading and storage areas in an industrial zone) containing 6,000 square feet of parking area shall provide interior landscaping in addition to the previously required VUA perimeter landscaping. Where a VUA is altered or expanded to increase to 6,000 or more square feet of area, interior landscaping shall be provided for the entire VUA area. Planting adjacent to or within ten feet of a building is considered foundation planting and is not counted towards the requirements of this section. All interior VUA shall be planted at the following rate:
- a. A minimum of five percent interior VUA landscaping shall be provided in planting islands or peninsulas.
 - b. The minimum landscape area to be counted towards the requirements of this section shall be 64 square feet, with a minimum island or peninsula width of six feet.
 - c. Required landscape areas shall be dispersed throughout the VUA, with no area being larger than 400 square feet, areas over this amount are permitted when in excess of the required five percent.

Article 4

Zoning Districts – Commercial and Office/Professional

- d. Landscape islands shall be required at the ends of all parking bays.
 - e. A minimum of one tree shall be planted within each landscape island or peninsula for each 250 square feet of required interior VUA landscaping.
 - f. There shall be no more than 20 parking spaces between islands or peninsula in a VUA. This is to include parking adjacent to common property lines or public rights-of-way.
7. **Screening of Service Structures.** All service structures shall be fully screened except when located in a RS-1, RM-2, LI or HI zoning district. Service structures for both LI or HI zone shall be fully screened when located within 100 feet of any zone except LI or HI.
- a. A continuous planting, fence, wall, or earth berm shall enclose any service structure on all sides unless such structure must be frequently moved, in which case screening on all but one side is required. The average height of the screening material shall be one foot more than the height of the enclosed structure, but shall not be required to exceed eight feet in height. No screening shall be required if the service structure is interior to loading or vehicle servicing area.
 - b. When plant material is to be used for the screening of service structures, the plant material must be able to provide 100 percent screening within three years.
 - c. All trash disposal units and ground level storage units shall be enclosed within walls, vegetation, or earthen berm on all sides with an opening door for the removal of trash or stored items. The height of the screening shall be 18 inches higher than the structure to be screened, but shall not be required to exceed eight feet in height.
8. **Landscape materials.** Screening material shall consist of plant material, wood, stone, masonry material, or earthen berm.
- a. All plant material shall meet the American Nursery Standards and shall come from the plant list available from the City-County Planning Commission Landscape Architect. If plant material not on the plant list is to be used, it must have the prior approval of the City-County Landscape Architect. All deciduous trees must be a minimum of one-and-three-quarter inches in caliper at planting, all evergreen trees shall be a minimum of five feet planted height, and shrubs shall be a minimum of 24 inches planted height. Ornamental trees shall have a minimum height of six feet planted height.
 - b. Fence or Wall material shall consist of either board-on-board wooden fence, masonry, or stone or any combination of the

above. The use of such wall or fence material used between incompatible land uses must be to a height of six feet and may be used in place of the evergreen trees and shrub material. The minimum buffer widths are still to be maintained and the deciduous tree requirements are to be used in conjunction with the wall or fence. All wood used is to be treated with water-borne preservatives to the American Wood Preservers Institute standards. All hardware is to be galvanized or otherwise rustproof. Chain link fencing may not be used to satisfy the requirements of this Section.

- c. Earthen berms shall be constructed to a maximum slope ratio of three to one (3:1) and covered with a ground cover or turf. A difference in elevation between areas requiring screening does not constitute an earth berm. The minimum buffer widths are still to be maintained and the deciduous tree requirements are to be used in conjunction with the wall or fence.

- 9. **Credit for existing vegetation.** Existing vegetation which is proposed to be used to fulfill the landscape requirements shall be shown on the required landscape plan, and may only be used with written approval of the City-County Landscape Architect after a site visit. All vegetation to be used must be on the property requiring the landscape plan. If in the future, the existing vegetation is removed, the property owner will be required to replace the vegetation with the quantity as outlined elsewhere in this section.

10. **Requirements of a Landscape Plan.**

- a. Site plan, drawn to a scale not to exceed one inch to fifty feet, showing all existing structures, proposed structures, proposed VUA and travel lanes, property lines, easements, existing topography, proposed grading at a minimum of two-foot contours and the proposed location of all plant material keyed to the plan.
- b. Plant schedule including common name, botanic name, cultivar, size and quantity, condition (balled and burlaped, container size or bare root), and planting details using the standards of the American Society of Landscape Architects.
- c. All adjacent property owners, land use, current zoning, and proposed zoning.
- d. All sites with more than 6,000 square feet of VUA and less than one-and-one-half acres shall require the professional seal and signature of either an Engineer, Architect, or Landscape Architect licensed to practice in the State of Kentucky, or Certified Kentucky Nurserymen. Any site with either 40,000 square feet or more of VUA or larger than one-and-one-half acres shall require the seal and signature of a

Landscape Architect licensed to practice in the State of Kentucky.

11. **Landscape plans required for building permit.**

- a. When a landscape plan is required, no building permit shall be issued until the required landscape plan has been submitted and approved, with a surety posted. This surety may be either a full cash bond or irrevocable letter of credit from a banking institution with offices in Warren County is submitted to the City-County Planning Commission in the amount of the cost to install the landscaping according to the approved landscape plan plus an additional fifteen (15) percent inflationary factor. All required landscape improvements must be installed within 90 days of receipt of a Certificate of Occupancy. The developer of the property may request in writing and be granted up to three, one month extensions if weather conditions prohibit the planting of the approved landscape plan.

12. **Maintenance.** All landscaping required by this Section and any landscape material planted as part of any Binding Elements, must be maintained in a healthy and growing condition, and all plant material that dies must be replaced in the next appropriate planting season to the specifications of the originally approved landscape plan.

13. **Appeals.** Any landscape plan disapproved by the City-County Landscape Architect, because the plan does not meet the requirements of this Article, may be appealed within 60 days of such action to the Board of Adjustments. The Board of Adjustments, in its review shall base its decisions to overrule the decision of the City-County Landscape Architect subject to meeting the following criteria:

- a. The strict application of the provisions of this ordinance would deprive the applicant of a reasonable use of the land or would create unnecessary hardship on the applicant.
- b. Such special circumstances are not the result of action of the applicant subsequent to the adoption or amendments of this section.
- c. Reasons that a variance will not adversely affect the public health, safety and welfare, and will not alter the essential character of the general vicinity, and will not cause a hazard or a nuisance to the public.

E. Off-Street Parking and Loading. Off-street vehicle storage or parking space shall be provided for all uses allowed in the districts in this Section. Such space shall be provided with vehicular access to a street or alley and shall be designated on any required site plan or Detailed Development Plan.

1. **Required Spaces.** The following are minimum requirements for specific uses. All measurements utilizing square feet shall be square

Article 4

Zoning Districts – Commercial and Office/Professional

feet of gross floor area unless otherwise expressly stated. Combined uses shall be required to provide parking equal to the total requirements for the individual uses. Where necessary, calculations shall be based on Kentucky Building Code Occupancy load requirements. Uses in the CB district are exempt from the on-site parking requirements of this Section.

Use	Spaces Required
Auto Showroom or Dealer, New or Used	1 per 400 square feet of showroom and office space, plus two spaces per service bay
Bed and Breakfast	1 space per bedroom
Conference Center or Student Center	1 space per 150 square feet of main meeting room space, whichever is greater.
Day Care	1 space per 400 square feet, exclusive of kitchens and bathrooms
Dormitory	2 spaces per 3 occupant beds, plus 1 space per employee
Hospital	1 space per 4 authorized beds, plus 1 space per 1,000 square feet
Hotel or Motel	1 per bedroom plus 1 per 400 square feet of banquet, office, or meeting space
Library, Museum, Art Gallery	1 per 1,000 square feet, plus 5 for each meeting or special facility room
Medical Office, Health Clinic, Pharmacy	1 space per 200 square feet
Nursing Home, Assisted Living	1 space per 4 authorized beds plus 1 space per 1,000 square feet
Office	1 space per 300 square feet
Place of Public Assembly (Auditorium, Place of Worship, Stadium, Theater, etc.)	1 space per 4 seats maximum capacity
Restaurant	1 space per 4 seats maximum capacity
Retail or Commercial Use	1 space for each 400 square feet
School, Elementary or Middle	2 spaces per classroom
School, Secondary or Post-Secondary	4 spaces per classroom, OR 1 space for 6 seats in auditorium, gym, arena or stadium, whichever is greater.

2. **Rules for Computing Requirements.** The following rules apply when computing off-street parking and loading requirements:
 - a. **Multiple Uses.** Lots containing more than one use must provide parking and loading in an amount equal to the total of the requirements for all uses.

- b. **Fractions.** When measurements of the number of required spaces result in a fractional number, any fraction of $\frac{1}{2}$ or less will be rounded down to the next lower whole number and any fraction of more than $\frac{1}{2}$ will be rounded up to the next higher whole number.
 - c. **Occupancy-Based Standards.** For the purpose of computing parking requirements based on employees, students, residents or occupants, calculations shall be based on the largest number of persons working on any single shift, the maximum enrollment or the maximum fire-rated capacity, whichever is applicable and whichever results in the greater number of spaces.
 - d. **Business Vehicles.** When parking spaces are used for the parking of vehicles for sale, in storage or used in the operation of a business, such parking spaces shall be provided in addition to those otherwise required by this Ordinance. Parking spaces for business vehicles shall conform to all of the standards of this Section.
 - e. **Unlisted Uses.** Upon receiving an application for a use not specifically listed in the table above, the Zoning Administrator shall apply the off-street parking standard specified for the listed use that is deemed most similar to the proposed use or require an alternative parking study in accordance with this section.
3. **Alternative Parking Study.** Some uses have widely varying parking demand characteristics, making it impossible to specify a single off-street parking standard. A developer proposing to develop or expand such a use may submit an alternative parking study that provides justification for the number of off-street parking spaces proposed.
- a. A parking study must include estimates of parking demand based on recommendations of the Institute of Traffic Engineers (ITE), or other acceptable estimates as approved by the Planning Commission Engineer and should include other reliable data collected from uses or combinations of uses that are the same as or comparable with the proposed use. Comparability will be determined by density, scale, bulk, area, type of activity, and location. The study must document the source of data used to develop the recommendations.
 - b. The Planning Commission Engineer shall review the parking study and any other traffic engineering and planning data relevant to the establishment of an appropriate off-street parking standard for the proposed use. After reviewing the parking study, the Planning Commission Engineer shall establish a minimum off-street parking standard for the proposed use.

Article 4

Zoning Districts – Commercial and Office/Professional

- c. In addition to minimum parking required per parking study, the Planning Commission Engineer may require additional, unpaved area be designated and set aside for future use.

4. Parking Space Design

- a. **Space Size.** The following minimum standards shall apply to the width and length of parking spaces.

Type	Width	Length
Standard parking space	9 feet	18 feet
Parallel parking space	8 feet	22 feet

- b. **Angle Parking Size.** The standards for the minimum width of parking spaces plus the aisle are shown in the following table. These standards apply to a single row of head-in parking or two rows of head-in parking sharing an aisle.

Angle	Width: 1 Row With Aisle	Width: 2 Rows Sharing Aisle
90 degree angle parking	42.0 feet	60.0 feet
60 degree angle parking	34.6 feet	54.7 feet
45 degree angle parking	31.1 feet	50.0 feet
30 degree angle parking	28.8 feet	45.6 feet

- c. **Driveways.** When driveways are less than 20 feet in width, marked separate entrances and exits shall be provided so that traffic shall flow in one direction only. Entrances and exits to an alley may be provided if prior approval is obtained in writing from the Planning Commission Engineer. Driveways designated as fire lanes shall meet the standards of the Fire Code.

Article 4

Zoning Districts – Commercial and Office/Professional

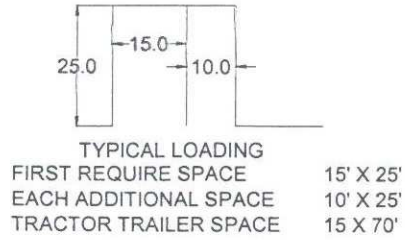
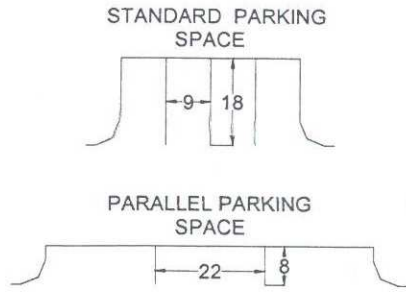

PARKING SPACE DESIGN

LOADING SPACE

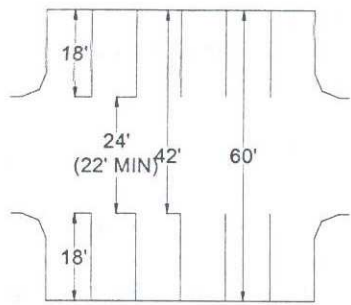

**90° ANGLE PARKING
(TWO WAY TRAFFIC)**

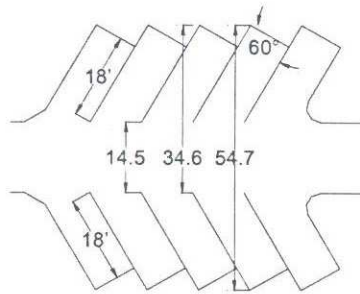

**60° ANGLE PARKING*
(ONE WAY TRAFFIC)**

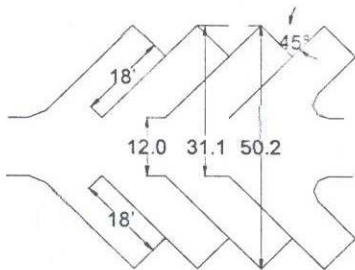

**45° ANGLE PARKING*
(ONE WAY TRAFFIC)**

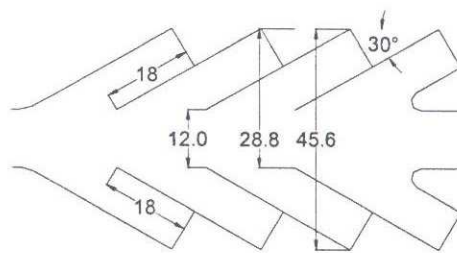

**30° ANGLE PARKING*
(ONE WAY TRAFFIC)**

ANGLE PARKING SIZE

NOTE:
MINIMUM AISLE WIDTH FOR TWO WAY TRAVEL AISLE SHALL BE 22'
MINIMUM ONE WAY SHALL BE AS SHOWN ABOVE

- d. **Maneuvering Space.** Maneuvering space shall be located completely off the right-of-way of a public street, place or court, and have a minimum width of 22 feet. Parking areas that would require the use of public right-of-way for maneuvering shall not be acceptable as required off-street parking spaces other than for one- and two-family dwellings. Parking parallel to the curb on a public street shall not be substituted for off-street parking requirements.
 - e. **Parking Surface.** Drives and parking spaces must be paved with concrete, asphalt, or brick pavers.
5. **Off-Site (Remote) Parking.** If sufficient parking is not available on the premises, a private parking lot may be provided within 500 feet, either on property zoned for that purpose or on approval as a conditional use by the Board of Adjustments subject to the following conditions:
- a. The parking shall be subject to the front yard setback requirements of the district in which it is located.
 - b. The parking area must be paved with concrete, asphalt, or brick pavers.
 - c. The parking area must be landscaped in accordance with the provisions of this Section.
 - d. Area lights must be directed away from adjacent properties.
 - e. **Agreement for Remote Parking.** A remote parking plan will be enforced through written agreement among all owners of record. An attested copy of the agreement between the owners of record must be submitted to the Planning Commission for recording and recording of the agreement must take place before issuance of a building permit for any use to be served by the off-site parking area. A remote parking agreement may be revoked only if all required off-street parking spaces will be provided in accordance with this Section.
6. **Shared Parking.** Developments or uses with different operating hours or peak business periods may share off-street parking spaces if approved as part of a Parking Plan and if the shared parking complies with the all of following standards.
- a. **Location.** Shared parking spaces must be located within 600 feet of the primary entrance of all uses served, unless remote parking shuttle bus service is provided.
 - b. **Zoning District Classification.** Shared parking areas require the same or a more intensive zoning classification than required for the use served.

- c. **Shared Parking Study.** Those wishing to use shared parking as a means of satisfying off-street parking requirements must submit a shared parking analysis to the Planning Commission Engineer that clearly demonstrates the feasibility of shared parking. The study must address, at a minimum, the size and type of the proposed development, the composition of tenants, the anticipated rate of parking turnover and the anticipated peak parking and traffic loads for all uses that will be sharing off-street parking spaces.

 - d. **Agreement for Shared Parking.** A shared parking plan will be enforced through written agreement among all owners of record. An attested copy of the agreement between the owners of record must be submitted to the Planning Commission for recording and recording of the agreement must take place before issuance of a building permit for any use to be served by the off-site parking area. A shared parking agreement may be revoked only if all required off-street parking spaces will be provided in accordance with this Section.
7. **Stacking Spaces for Drive-Thru Facilities.** In addition to meeting the off-street parking requirements of this section, drive-thru facilities shall comply with the following minimum stacking space per lane standards:

Use Type	Minimum Spaces	Measured From
Automated teller machine	3	Teller
Bank teller lane	4	Teller or Window
Car wash stall, automatic	6	Entrance
Car wash stall, self-service	3	Entrance
Gasoline pump island	30 feet	Each end of pump island
Restaurant drive-thru	8	Pick up window
Other drive-through	3 spaces	Pick up window
Other	As approved by Planning Commission Engineer based on Parking Study	

Stacking spaces shall be subject to the following design and layout standards:

- a. Stacking spaces shall be a minimum of 8 by 20 feet in size.

- b. Stacking spaces shall be designed so as not to impede pedestrian circulation or on- and off-site traffic movements or movements into or out of parking spaces.

Article 4

Zoning Districts – Commercial and Office/Professional

- c. Stacking spaces shall be separated from other internal driveways with raised medians, if deemed necessary by the Planning Commission Engineer for traffic movement or safety.

- 8. **Off-Street Loading Space.** Every building or structure hereafter constructed for business or trade use shall provide adequate space for the loading or unloading of delivery vehicles on site. Such space shall have access to a public alley, or if there is no alley, to a public street. The Central Business and Office Professional - Residential districts shall be exempt from the off-street loading space requirements.

District	Minimum Off-Street Loading Space
NB, GB, HB	1 space per 10,000 s.f. of building (or fraction thereof)
OP-C, P	1 space per building

F. Signs

- 1. The purpose of this Section is to create the legal framework for a comprehensive, but balanced, system of signs of all types and thereby to facilitate an easy and pleasant communication between the people and their environment. It is the intention of this Ordinance to regulate the number, location, size, height, and illumination of on-premises signs.

- 2. The effect of this Section is:
 - a. To allow signs in all commercial zoning districts on a limited basis, subject to the standards and the procedures of this Section;

 - b. To prohibit signs not expressly permitted by this Section; and

 - c. To provide for the administration of the provisions of this Section.

- 3. **Application and Permits for On-Premise Signs**
 - a. All permanent and temporary on-premise signs shall require a permit. Permits shall be obtained from the Building Inspector of the appropriate jurisdiction. Prior to the issuance of a permit by the Building Inspector, the permit applications shall be approved by the Executive Director, or designee, in order to determine compliance with the Zoning Ordinance of Warren County and the Subdivision Regulations of Warren County as well as any recorded subdivision plat or development plan.

- b. The following on-premise signs shall not require a permit:
 - (1) On-premise signs which are in the public interest and contain no commercial reference, such as safety signs, pedestrian and motor vehicle control signs; signs of historical significance; clocks; temporary construction, real estate, flags (including government, political subdivision, or other official designated flags of an institution or business), personal expression, and political campaign signs. These signs shall, however, otherwise comply with Section 4 (On-Premise Sign General Provisions) with regard to visibility and right-of ways.
 - (2) Personal expression signs shall be limited to a maximum of 16 s.f. in size. Campaign signs shall not exceed 16 square feet (32 square feet in unincorporated areas of Warren County) and may be displayed immediately following the filing for an election, and no more than 30 days after the election date. All Real Estate signs shall be limited to on-site signs where property is for sale. This type of sign shall not exceed 32 square feet in sign area and no larger than 7 feet in height. Temporary off-premise Real Estate signs used as directional signs may be allowed for a period not to exceed 30 days prior to sale or auction date. Temporary construction signs shall be limited to a maximum of 16 s.f. in size. Flags of any other official designated institutions or business shall utilize freestanding flag poles, no taller than 40 feet in height; flag size shall not to exceed 120 square feet in area for each flag. Integral signs shall be exempt from the provisions of this Section.

4. **On-Premise Sign General Provisions**

- a. All on-premise signs shall conform to the sign standards provided in the Sign Standards Summary Table unless otherwise excepted in this Section. The sum of all sign faces on a freestanding sign shall not exceed twice the maximum permitted sign area as set forth in this Section or the Sign Standards Summary Table.
- b. **Freestanding Signs** – The area of a sign shall include all lettering, wording, designs and symbols, together with a background, whether open or enclosed, on which they are displayed. The supporting structure or bracing of a sign shall be omitted in measuring the area of the sign unless such structure or bracing is made part of the message or face of the sign.
- c. **Wall Signs** – Where a sign consists of individual letters, words or symbols attached to a surface, building, canopy,

Article 4

Zoning Districts – Commercial and Office/Professional

awning or wall and such elements are located in the same plane, the sign area shall be the area of the smallest rectangle which completely encompasses all such letters, words or symbols and any accompanying background of a color different than the natural color of the wall.

- d. No sign shall be erected to obstruct free and clear vision of an intersection and/or traffic signals. No sign may be placed in or extended over a public right-of-way or utility easement without the express written consent of the controlling jurisdiction or utility.
- e. All freestanding signs shall be set back a minimum of 20 feet from the edge of pavement. If the principal structure is located less than 20 feet from the edge of pavement, the sign shall be affixed to the flat surface of the building.
- f. Nonconforming businesses shall be allowed to have or to replace existing on-premise signs, except when such signs violate the provisions of this Section.
- g. No on-premise sign shall be erected within 50 feet of an abutting residential district.
- h. No on-premise signs shall be permitted which exceed the intensity of illumination of 0.5 foot candles measured at five feet above grade at 20 feet from the sign. No sign shall have a flashing light or a light resembling any law enforcement or emergency vehicle light or revolving lights that will resemble any stop light, signal light, or traffic light.
- i. No on-premise sign shall contain commercial advertising which is unrelated to the existing use of the property.
- j. Wall or building signs may be placed on the vertical facade or the roof of the building, but shall not extend above the roof line and shall be permitted in addition to any other permitted sign except in the residential districts and the office and professional districts.
- k. Temporary signs such as: Banners, pennants, posters, flags (excluding government, political subdivision, or other official designated flags of an institution or business), fixed balloons, or similar devices shall be permitted if the devices are solely affixed to a window or the principal facade of the building and does not extend above the roof line.
- l. All non-residential buildings which utilize a freestanding sign shall incorporate a street address number or address range. Street address numbers shall be of a letter height specified by the Planning Commission. Street address number or address range shall be placed on freestanding monument signs,

where applicable. The area of the address number shall not be computed as part of the sign face.

- m. The height of a sign shall be computed as the distance from the base of the sign at a computed grade to the top of the highest attached component of the sign (including the sign face, sign structure, or any other appurtenance). The computed grade shall be the elevation of the nearest point of the crown of the closest public street.
- n. All signs shall be constructed of durable materials such as: high quality plastic, finished metal, stone, brick, decorative block, finished wood or EFIS. Pylon pole covers are encouraged for freestanding pole signs.
- o. All freestanding signs shall be shown on any required landscape plans and site and development plans. The area immediately surrounding any ground signs shall be kept cleared of unsightly debris. Landscaping is encouraged in this area, provided that the selected landscape materials will not grow to obscure the sign face or building address.

5. Prohibited Permanent On-Premise Signs

- a. On-premise signs erected, maintained, or continued which cause any interference to sight distance;
- b. Portable signs (signs with no permanent attachment to a building or the ground, including but not limited to, A-frame signs, pole attachments, searchlights, and stands) on wheels or freestanding, shall not be allowed permanently on any site;
- c. Banners, posters, pennants, flags (excluding, government, political subdivision, or other official designated flags of an institution or business), large fixed balloons, or similar devices affixed to any independent support, fence, awning, pump canopy, curbstone, lamp post, utility pole, hydrant, bridge, culvert, public drinking fountain, public trash container, rest station building, tree, or in or on any portion of any public sidewalk, street, or sign shall be prohibited as permanent on-premise signs.
- d. Animated signs, defined as signs with externally moving parts or messages, or so operating as to give a viewer the illusion of moving parts or messages are prohibited. Official signs for safety purposes shall be exempt from this restriction.
- e. Signs which are obscene, indecent, or immoral are prohibited.
- f. Signs are prohibited that are made of paper or cardboard erected outside a completely enclosed building, except for any sign permitted by this Section that is constructed in a manner in which it does not rapidly deteriorate from rain or

Article 4

Zoning Districts – Commercial and Office/Professional

- other elements, is maintained in good condition and is promptly repaired or removed if it deteriorates.
- g. Roof signs, defined as a sign erected, constructed and maintained wholly upon or over the roof of any building are prohibited. Mansard roof signs that do not extend above the parapet wall of the roof shall be considered wall signs.
 - h. Signs (other than approved community banners and those erected by a governmental agency or required to be erected by a governmental agency or its contractual agent) erected on the right-of-way of any public street, road, or way, or signs overhanging or infringing upon the right-of-way of any public street, road, or way, are prohibited except as specifically provided in this Section.
 - i. Signs erected on public property other than signs erected by public authority for public purposes are prohibited.
 - j. Signs so located as to prevent free ingress or egress from any door, window, or fire escape are prohibited. No sign shall be attached to a standpipe or fire escape.
 - k. Signs that emit any sound, visible or invisible gases, or odor as part of any message.
 - l. Signs on or attached to utility poles or trees, shrubs, or plants are prohibited except that approved community banners may be attached to utility poles.
 - m. Signs incorporated into trucks, motor vehicles, trailers and similar equipment bearing advertising visible from off-site and parked at the business location for the intended purpose of advertising a business, service or product, are considered vehicle signs and are prohibited. Delivery and service vehicles or trailers used on a daily basis in conjunction with an on-site business are exempt when they are parked in a location that is not visible from off-site, or otherwise creates the least possible visual impact without significant effect on the security of the vehicle or trailer.
 - n. Any sign that is not expressly permitted in section 4.6.8.F is prohibited.
 - o. Any off-premise advertising signs, except as specifically permitted by this Section are prohibited.
6. **Temporary On-Premise Signs.** Temporary Signs that are used for any special occasion or business Grand Opening such as: Banners, posters, pennants, flags (excluding government, political subdivision, or other official designated flags of an institution or business), wind signs (gas, cold air or hot air balloons; streamers; and rotating devices, fastened in such a manner to move upon being subjected to

pressure by wind or breeze) fixed balloons, or similar devices which are not solely affixed to a window or the principal facade, and portable signs on wheels or freestanding shall be permitted in all commercial zoning districts for a 30 day period not to exceed 4 times per calendar year.

7. **Permanent On-Premise Signs**

- a. Integral signs, motor vehicle control signs, identification signs, and entrance signs are permitted in all commercial zoning districts.
- b. **High-Rise Signs.** Property zoned Highway Business (HB) or Industrial (LI or HI) and located within the general vicinity of the Scottsville Road/Interstate 65 interchange, the Louisville Road/Interstate 65 interchange or the Smiths Grove/Interstate 65 interchange may have a maximum of two freestanding signs, one which may be a high-rise sign. A high-rise sign is defined as any sign between 50 and 100 feet in height. For the purposes of calculating the permitted areas, the maximum heights and sign face areas from the interchanges set forth above, Exhibits A1, A2 and A3 in Appendix A shall apply.

High-Rise Sign Area	High-Rise Sign Height	High-Rise Sign Area Sign Face
Exit 22-Scottsville Rd-Exhibit A1	100 feet	250 square feet
Exit 28-Louisville Rd-Exhibit A2	100 feet	250 square feet
Exit 38-Smiths Grove-Exhibit A3	85 feet	200 square feet

- c. **Historic District.** Signs in any Local Historic District shall require a Certificate of Appropriateness approved by the Historic Preservation Board. All on-premise signs shall conform to the sign standards provided in the Sign Standards Summary Table unless otherwise excepted in this Section. One identification sign per frontage is permitted and may be wall or canopy. One bulletin board is permitted per lot. Identification signs which are wall signs may be located in historically traditional locations, (i.e. on storefront beltcourses or on flat surfaces of the building); painted on glass elements; or hanging or mounted inside windows or door. Signs should be constructed of historic sign materials such as: finished, carved or sandblasted wood; glass; goldleaf; brass and/or copper letters; plastic or unfinished wood (not plywood). Signs should be limited to no more than 2 or 3 colors coordinating with the overall building colors. Signs should be of a style appropriate to the period of the building. Signs should utilize lettering not exceeding 18 inches in height or covering more than 60 percent of the total sign area. The canopy sign shall not project above the roof line nor above

the vertical canopy face. The more restrictive of the Historic District Overlay or the underlying district shall apply.

- d. **Entrance Signs.** The content of an entrance sign shall be limited to the name of the subdivision or residential complex only. No sign shall be internally illuminated. All entrance signs shall be constructed of durable materials. Landscaping is encouraged around entrance signs, provided the selected landscape materials will not grow to obscure sign face. **Structural Type and Size.** Any entrance sign must be monument type and the maximum sign face shall be 60 sq. ft. total. Maximum height shall be 5 feet. Entrance signs may be allowed in public right-of-way only with written permission of the applicable jurisdiction. The content of an entrance sign shall be limited to the name of the subdivision only. All permitted signs shall also comply with all the applicable Sign Development Standards in Section 4.6.8.F.
8. **Dangerous, Defective, Destroyed, Damaged, Removed or Abandoned On-Premise Signs.** Signs which are deemed dangerous or defective by the Building Inspector or other authorized Code Enforcement Officer shall be removed at the sole cost and expense of the property owner.
 9. **Existing On-Premise Non-Conforming Signs**
 - a. **Destroyed, Damaged, Removed, or Abandoned Signs.** Whenever a non-conforming sign collapses, burns, or is removed from its location, it shall not be replaced or reconstructed, except in full compliance with the provisions of this Section. Signs which have been abandoned or which advertise an establishment, service, or product which has not existed or been available at that location for a period of one year shall be removed by the property owner at their sole cost and expense.
 - b. Freestanding signs which are not prohibited on-premise signs and in legal existence on the effective date of this Section and not in conformity with the provisions may remain in place and shall be referred to as nonconforming signs. Only routine maintenance may be performed on the sign and its structure until such time as the sign is brought into conformance with these regulations. Routine maintenance is limited to replacement of nuts and bolts, cleaning and painting, or manipulating to level or plumb the device but not to the extent of adding struts or guys for the stabilization of the sign or structure or substantially changing the sign. The routine changing of messages is considered to be routine maintenance but the replacement of new or additional panels or replacing of facing shall not be considered routine maintenance.

- c. If the sign is destroyed beyond 55 percent of its replacement value, such sign can only be replaced or reconstructed in accordance with the requirements of this Ordinance and the Subdivision Regulations, as well as any recorded subdivision plat or development plan. Any sign which cannot be replaced or reconstructed in compliance with this Section shall be removed by the property owner at owner's sole cost and expense.

10. **Off-Premise Signs.**

Off premise signs are prohibited throughout Warren County except as Consolidated Shopping Center Signs allowed in Sec. 4.6.8.F.11 and as outdoor or billboard advertising signs allowed in Sec. 4.6.8.F.12. Off-premise Religious Institutional and Agriculture Related Product Signs (not to exceed 32 square feet) may be used as directional signs in unincorporated areas of Warren County.

11. **Consolidated Shopping Center Signs**

The following special regulations shall apply to on and off-premise signs for Shopping Centers zoned HB or Planned Unit Development.

- a. **Permitted Areas.** Any Retail Shopping Center (Combined retail space of a minimum of 100,000 sf) zoned HB or Planned Unit Development shall be allowed one freestanding identification sign at each entrance into the development from a collector or arterial street provided that:
 - (1) no identification sign shall be spaced closer than 600 feet from another identification sign for the same Shopping Center Development.
 - (2) location of the sign must be within 600 feet of the Shopping Centers Development, and
 - (3) no identification sign shall be placed so as to obstruct the sight distance.
- b. **Maximum Area.** The total area of the sign face for each side of the identification sign shall not exceed 200 square feet.
- c. **Maximum Height of Sign.** The maximum height of the identification sign shall not exceed 30 feet above the average ground level at the base of the sign.
- d. **Maintenance and Easement.** No off-premise identification sign shall be permitted before first having established an easement by plat or ownership of the property where the sign is to be located by fee simple absolute for the purpose of location of the sign. Further, said easement must include provisions for the maintenance, landscaping, and removal of the sign.

- e. **Content of Identification Sign.** Any Consolidated Shopping Center identification sign may carry the name, or a combination of names, of the major enterprise(s) or firm(s) located within the Shopping Center Development. No sign less than twelve (12) square feet in sign face area or sign that contains lettering less than eight inches in height shall be allowed on the identification sign. The content shall not exceed the total allowable sign face in b. above.
 - f. **Illumination.** Signs may be illuminated provided such illumination shall be effectively shielded so as to prevent beams or rays of light from being directed at any travel way, or which are of such intensity or brilliance as to cause glare or to impair the vision of the driver of any motor vehicle, or which otherwise interfere with any driver's operation of a motor vehicle. No sign shall be so illuminated that it interferes with the effectiveness of or obscures an official traffic sign, device, or signal.
 - g. **Sign Plan Required.**
 - (1) No building permit for a Consolidated Shopping Center sign may be issued without there having been approved an agreement between the affected property owners providing for the ongoing maintenance, construction standards and plan for locating the on-premise and off-premise signs. Any such agreement shall be in the form to be recorded in the office of the Warren County Clerk and shall contain provisions requiring it to run with the land for all purposes. Any such agreement shall contain a provision that it cannot be amended or repealed without the prior approval of the Planning Commission.
 - (2) In lieu of an agreement described in the preceding section, a Detailed Development Plan shall be approved by the Planning Commission setting for the maintenance, construction standards and plan for locating the on-premise and off-premise signs.
12. **Billboard Advertising Signs.**
The following special regulations shall apply to billboard advertising signs:
- a. **Permitted Areas.**
 - (1) **Interstate Billboards** – Interstate Billboards are limited to only portions of Interstate 65 and the William H. Natcher Parkway, as shown on exhibit B1. Minimum setback of any Interstate Billboard Sign shall be at least 660 feet along these roadways and shall be in compliance with all State and Federal

guidelines for Interstate Billboards. Interstate Billboards are limited to said highways in HB and industrial (LI and HI) zoning districts.

- (2) **Urban Billboards** – Urban Billboards are limited to only portions of U.S. Hwy. 31-W, 231, 68, KY 80, KY 880, and KY 185 (as shown on exhibit B2) in HB and industrial zoning districts.

b. **Maximum Area.**

- (1) **Interstate Billboards** – Interstate Billboards shall not exceed the total signable area of 1,600 square feet inclusive of any border and trim.
- (2) **Urban Billboards** – Urban Billboards shall not exceed the total signable area per face of 600 square feet inclusive of any border and trim (no more than 300 sf per sign).

c. **Maximum Height of Sign.**

- (1) **Interstate Billboards** – The maximum height shall be 60 feet above the average ground level at the base of the sign for all Interstate Billboards.
- (2) **Urban Billboards** – The maximum height shall be 40 feet above the average ground level at the base of the sign for all Urban Billboards.

d. **Maximum Width.**

- (1) **Interstate Billboards** – The maximum width shall be 40 feet for all Interstate Billboards.
- (2) **Urban Billboards** – The maximum width shall be 50 feet for all Urban Billboards.

e. **Sign Structure Configuration.** Sign structures may be constructed back to back or V-shaped. Signs may be double-stacked, as long as, they meet area, height and width requirements in items b, c and d.

f. **Spacing Per Sign Structure.** No billboard sign shall be located within 500 feet of another billboard sign (on each side of the roadway) as measured along the centerline of the parkway, interstate, or arterial highway on which such signs are located.

g. **Illumination.** Signs may be illuminated provided such illumination shall be effectively shielded so as to prevent beams or rays of light from being directed at any travel way, or which are of such intensity or brilliance as to cause glare or

to impair the vision of the driver of any motor vehicle, or which otherwise interfere with any driver's operation of a motor vehicle are prohibited. No sign shall be so illuminated that it interferes with the effectiveness of or obscures an official traffic sign, device or signal.

- h. **Billboard Sign Lot Requirement.** All billboard signs must be located on an individual lot, consisting of at least 5,000 square feet. All sign structures shall be considered principal structures for purposes of this Ordinance and shall be the sole structure on the lot. Such lots must meet all dimensional requirements (frontage, width, setbacks, etc) of the specific zoning district in which the sign is located. Adequate water and sewer capacity shall not be required for such lots.
- i. **Cut-outs or Extensions.** Cutouts or extensions of a non-permanent nature shall not exceed 60 square feet and shall not exceed six (6) feet in height nor ten (10) feet in width (added to the top of the display face). Cutouts or extensions which would extend along the entire top of the signable area and thereby increase the overall height or width of the sign face shall be considered of permanent nature and shall be prohibited. No cut-outs or extensions shall be added to the sides or bottom of the sign face.

G. Outdoor Storage. Outdoor storage and display shall be allowed in any commercial district in accordance with this Section. Any merchandise, material or equipment situated outdoors shall be subject to the requirements of this Section. Such storage shall not include junk, trash, garbage or other general debris. For the purpose of this section, outdoor storage and display shall be broken down into three types, as follows:

- 1. **Type 1: Outdoor Display.** Type 1 Outdoor Display shall be allowed adjacent to a principal building wall and extending to a distance no greater than 5 feet from the wall. Such storage shall not be permitted to block windows, entrances or exits, and shall not impair the ability of pedestrians to use the building.
- 2. **Type 2: Limited Outdoor Storage.** Type 2 Limited Outdoor Storage shall not exceed 5 percent of the total site area.
- 3. **Type 3: General Outdoor Storage.** Type 3 General Outdoor Storage shall not be allowed in commercial districts and is allowed in industrial districts only.
- 4. **Type 4: Temporary/Seasonal Outdoor Storage.** Type 4 Temporary/Seasonal Outdoor Storage may exceed the limits for Outdoor Storage but shall require a permit from the Building Inspector and shall be limited to a 30 day period no more than 4 times per year.

5. Exceptions.

- a. Vehicles for sale (including boats) shall not be considered merchandise, material or equipment subject to the restrictions of this Section. However, all vehicle storage shall be located on the property and not on public right-of-way.
- b. Manufactured housing or model homes that are displayed in a semi-permanent state with permanent landscaping and skirting shall not be considered merchandise, material or equipment subject to the restrictions of this Section.
- c. Waste generated on-site and deposited in ordinary refuse containers shall not be subject to the restrictions of this Section.
- d. Areas enclosed by solid, opaque walls on at least three sides and covered by a solid, opaque roof shall not be considered outdoor.

6. Location of Outdoor Storage and Display.

- a. All outdoor storage and display shall be located outside the public right-of-way and/or at least 15 feet from the back edge of the adjacent curb or street pavement.
- b. Outdoor storage and display areas shall be paved and meet all landscaping requirements of the ordinance.
- c. No outdoor storage or display shall be allowed in required side yard setback.
- d. Any temporary/seasonal outdoor storage shall not utilize any parking space required for the principal use of the property.

7. Allowed Storage Table. The three types of storage shall be allowed in the districts designated in the Table below:

TYPE	NB	GB	CB	HB	OP-R	OP-C
Type 1: Outdoor Display	✓	✓	✓	✓	--	✓
Type 2: Limited Outdoor Storage	--	✓	--	✓	--	--
Type 3: General Outdoor Storage	--	--	--	--	--	--
Type 4: Temporary/Seasonal	✓	✓	✓	✓	--	✓

H. Outdoor Lighting and Speakers.

- 1. All lighting fixtures designed or placed so as to illuminate any portion of a site shall meet the following requirements:

Article 4

Zoning Districts – Commercial and Office/Professional

- a. **Fixtures.** All light sources shall be concealed within an opaque housing and shall not be visible from any public right-of-way or residential district boundary.
 - b. **Mounting.** Fixtures must be mounted in such a manner that the cone of light does not cross any property line of the site.
 - c. **Illumination Levels.** All site lighting shall be designed so that the level of illumination, measured in footcandles (fc) at any one point meets the standards for the specific use below. Minimum and maximum levels are measured at a single point. Average level is the not-to-exceed value calculated using only the area intended to receive illumination.
 - d. **Canopy Lighting.** Any lighted canopy (fuel sales, automated teller machines, etc.) shall be illuminated with an average 12 fc, a minimum of 2 fc, and a maximum of 20 fc.
 - e. **Commercial Parking Lots.** All commercial parking lots shall be lighted with an average 1.5 fc, a minimum of 0.2 fc, and a maximum of 10 fc.
2. Outdoor paging and speaker systems are prohibited except for emergency warning systems and at drive-through windows meeting the specific use criteria in Sec. 5.2.
- I. **Height Limit Exceptions.** The height limitations of this Ordinance shall not apply to church spires, belfries, cupolas and domes not intended for human occupancy; monuments, water towers, observation towers, flag poles, radio and television towers, masts, aerials, chimneys and smoke stacks.
- J. **Accessory Building Standards.** Accessory buildings, except as otherwise permitted by this Ordinance, shall require a building permit and shall be subject to the following regulations in all commercial zoning districts.
1. When a corner lot adjoins another lot in the rear which is used for residential purposes, no accessory building or structure shall extend beyond the front of the principal structure or be nearer to the side street than the depth of any required front yard for a dwelling along such side street, again excluding fences 4 feet or less in height.
 2. Where the accessory building is structurally attached to the principal building, it shall be subject to, and shall conform to, all regulations of this Ordinance applicable to the principal building.
 3. An accessory building may not exceed the height of the principal structure.
 4. The total of all accessory buildings shall not exceed 50 percent of the ground floor area of the principal building.

Article 4

Zoning Districts – Commercial and Office/Professional

5. No detached accessory building shall be located closer than 10 feet to any principal building, and may require greater separation when requested by the Fire Marshal.
6. An accessory building may be connected to the principal building by a breezeway or other similar structure but shall not project nearer the side lot line than the minimum side yard required for the main building.
7. Accessory buildings/structures shall be permanently affixed to the ground and shall not include mobile home, bus, travel trailer, RV, trailer, cooler, vehicle or freight container. Ground level storage units are excluded from the requirement to be permanently affixed to the ground and shall be allowed in commercial districts with appropriate screening as outlined in Sec. 4.6.8.D.

K. Horizontal Property (Condominium)

1. The intent and application of this Ordinance is to implement and reaffirm the Horizontal Property Law of Kentucky (KRS 381).
2. A master deed or lease or floor plans meeting the standards set forth in KRS 381 shall not be filed in the office of the Warren County Clerk without having first been reviewed and approved by the Planning Commission.
3. The maximum permitted overall densities and floor area ratios and the minimum outdoor area, living space, and recreation area ratios shall be controlled by the zoning district classification in which the project is located.
4. The establishment, expansion or diminution of a horizontal property regime shall be subject to review and approval by the Planning Commission in the same manner as approval of a detailed development plan.

SEC. 4.7 INDUSTRIAL DISTRICTS

4.7.1 Light Industrial District (LI)

The Light Industrial District is intended to provide areas segregated for industrial use where processes and equipment employed and goods processed are limited to those which are not objectionable by reason of odor, dust, smoke, cinders, gas fumes, noise, vibration, refuse matter or water-carried waste.

4.7.2 Heavy Industrial District (HI)

The Heavy Industrial District is intended to provide opportunities for the development of industry which may have significant external impacts due to noise, glare, heat, odor, dust, vibration or hazardous materials.

4.7.3 General Industrial Development Standards

A. Uses. Uses permitted in each District are shown in the Use Table in Sec. 5.1. This table employs broad use categories containing a variety of similar uses. The use categories are described in Sec. 5.2, Use Categories, and Appendix B lists examples of uses, showing which use categories they fall into. Additional standards for specific uses, if any, can be found in each category.

B. Property Development Standards.

1. Development in each District shall comply with the industrial development standards in the following table:

	LI	HI
Lot Area, min. sq. ft.		
Public Sewer	5,000	5,000
Septic System *	130,680	130,680
Lot Width, min. ft. at Bldg. Line	50	50
Lot Frontage, min. ft.	50	50
Lot Coverage, max. %	90%	90%
Setbacks, min. ft.		
Front Yard	25	25
Side Yard	0	0
Rear Yard	0	0
Height, max. ft.	50	100
Building Size, max. sq. ft.	N/A	N/A
Parking	1 per employee maximum shift	1 per employee maximum shift
Min. Fire Flow Required?	600 GPM	600 GPM
Landscaping Required	See Section 4.6.8.D for requirements	

Article 4

Zoning Districts – Industrial

	LI	HI
Residential Uses Allowed?	No	No

* Maximum building size with on-site septic system shall be 6,000 s.f.

2. **Minimum Lot Area Above 100-Year Flood Level Required.** No lot served by public sanitary sewer shall be created or developed which does not have at least 5,000 square feet of lot area above the 100-year frequency flood level. No lot served by on-site septic systems shall be created or developed which does not have at least 20,000 square feet of lot area above the 100-year frequency flood level.

C. Additional Setback Adjacent to Residential District. Development in any industrial district adjacent to the boundary of a residential zoning district shall require the following setbacks:

1. The LI District shall require a 25-foot side and rear yard where abutting a residential district.
2. The HI District shall require a 50-foot side and rear yard where abutting a residential district.

D. Landscaping. All industrial development shall comply with the minimum landscaping standards as set forth in the Commercial Development Standards in Section 4.6.8.D.

E. Off-Street Parking and Loading. Off-street vehicle storage or parking space shall be provided on any lot on which any of the following uses are hereafter established; such space shall be provided with vehicular access to a street or alley.

1. **Required Spaces.** The following are minimum requirements for specific uses. All measurements utilizing square feet shall be square feet of gross floor area unless otherwise expressly stated. Combined uses shall be required to provide parking equal to the total requirements for the individual uses. Where necessary, calculations shall be based on Kentucky Building Code Occupancy load requirements.

Industrial Use	Spaces Required
Industrial Plant	1 space per employee, maximum shift
Wholesale, Storage or Warehousing	1 space per employee, maximum shift

2. **Computation and Design.** All parking required under this Section shall comply with Section 4.6.8.E. of the Commercial Development Standards with regard to computing parking requirements, alternative parking study, parking space design, off-site parking, and shared parking.

Article 4

Zoning Districts – Industrial

3. **Parking Surface.** Drives and parking areas and spaces must be paved with concrete, asphalt, or brick pavers.

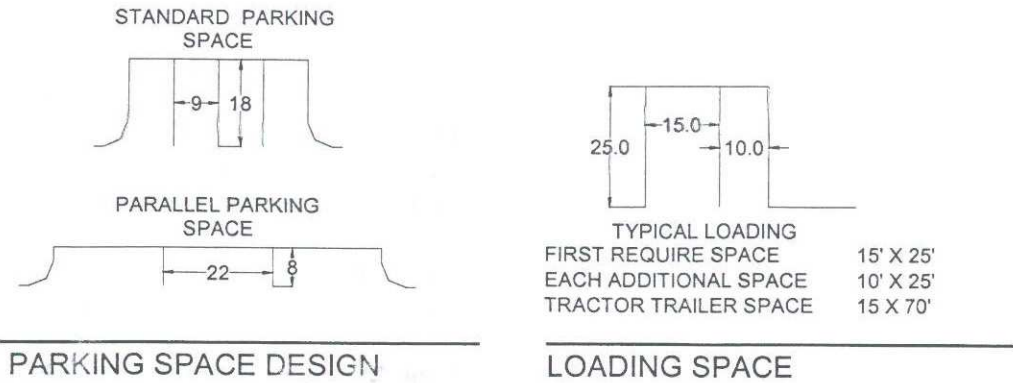

PARKING SPACE DESIGN

LOADING SPACE

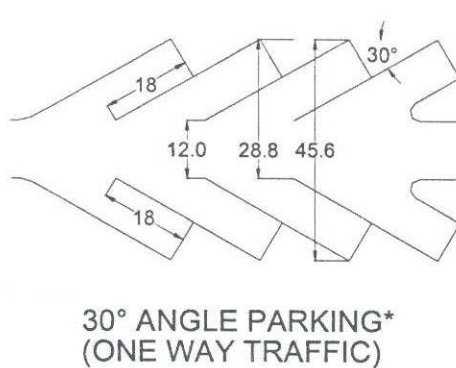
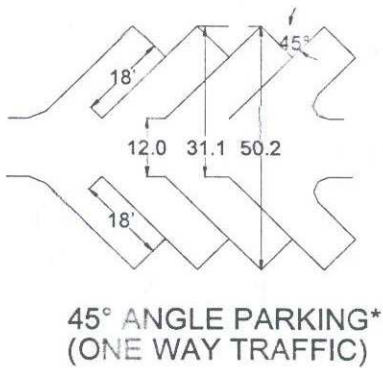
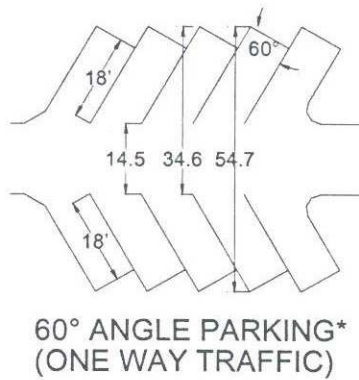
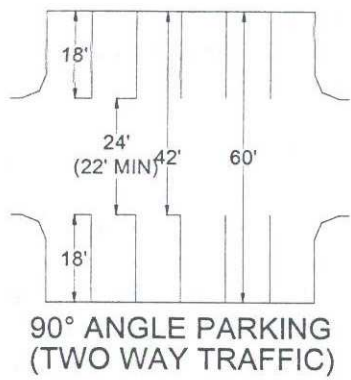

ANGLE PARKING SIZE

NOTE:
 MINIMUM AISLE WIDTH FOR TWO WAY TRAVEL AISLE SHALL BE 22'
 MINIMUM ONE WAY SHALL BE AS SHOWN ABOVE

Article 4

Zoning Districts – Industrial

4. **Off-Street Loading Space.** Every building or structure hereafter constructed for business or trade use shall provide adequate space for the loading or unloading of delivery vehicles on site. Such space shall have access to a public alley, or if there is no alley, to a public street.

District	Minimum Off-Street Loading Space
LI, HI	1 space per each 20,000 s. f. (or fraction thereof) of building

5. **Signs.** All signs in the Industrial Districts shall comply with Section 4.6.8.F. of the Commercial Development Standards.

6. **Outdoor Storage.** Outdoor storage and display shall be allowed in any industrial district in accordance with this Section. Any merchandise, material or equipment situated outdoors shall be subject to the requirements of this Section. Such storage shall not include junk, trash, garbage or other debris. For the purpose of this section, outdoor storage and display shall be broken down into three types, as follows.

- a. **Type 1: Outdoor Display.** Type 1 Outdoor Display shall be allowed adjacent to a principal building wall and extending to a distance no greater than 5 feet from the wall. Such storage shall not be permitted to block windows, entrances or exits, and shall not impair the ability of pedestrians to use the building.
- b. **Type 2: Limited Outdoor Storage.** Type 2 Limited Outdoor Storage shall not exceed 1,000 square feet or 10 percent of the total site area (whichever is greater) in addition to any Type 1 Outdoor Display on the site.
- c. **Type 3: General Outdoor Storage.** Type 3 General Outdoor Storage shall be allowed in unlimited quantity, subject only to the location restrictions below.
- d. **Type 4: Temporary/Seasonal Outdoor Storage.** Type 4 Temporary/Seasonal Outdoor Storage may exceed the limits for Outdoor Storage but shall require a permit from the Building Inspector and shall be limited to a 30 day period no more than 4 times per year.
- e. **Exceptions.**
 - (1) Waste generated on-site and deposited in ordinary refuse containers shall not be subject to the restrictions of this Section.

Article 4

Zoning Districts – Industrial

- (2) Areas enclosed by solid, opaque walls on at least three sides and covered by a solid, opaque roof shall not be considered outdoor.

f. **Location of Outdoor Storage and Display.**

- (1) All outdoor storage and display shall be located outside the public right-of-way and/or at least 15 feet from the back edge of the adjacent curb or street pavement.
- (2) No outdoor storage or display shall be allowed in required side yards.
- (3) Any temporary/seasonal outdoor storage shall not utilize any parking space required for the principal use of the property.

- g. **Allowed Storage Table.** The three types of storage shall be allowed in the districts designated in the Table below:

TYPE	LI	HI
Type 1: Outdoor Display	✓	✓
Type 2: Limited Outdoor Storage	✓	✓
Type 3: General Outdoor Storage	✓	✓
Type 4: Temporary/Seasonal Storage	✓	✓

F. **Outdoor Lighting and Speakers.**

- 1. All lighting fixtures designed or placed so as to illuminate any portion of a site shall meet the following requirements.
 - a. **Fixtures.** All light sources shall be concealed within an opaque housing and shall not be visible from any public right-of-way or residential district boundary.
 - b. **Mounting.** Fixtures must be mounted in such a manner that the cone of light does not cross any property line of the site.
 - c. **Illumination Levels.** All site lighting shall be designed so that the level of illumination, measured in footcandles (fc) at any one point meets the standards for the specific use below. Minimum and maximum levels are measured at a single point. Average level is the not-to-exceed value calculated using only the area intended to receive illumination.
- 2. Outdoor speaker systems must be limited so that it is not audible at the property line adjacent to any residential district.

- G. Height Limit Exceptions.** The height limitations of this Ordinance shall not apply to church spires, belfries, cupolas and domes not intended for human occupancy; monuments, water towers, observation towers, flag poles, radio and television towers, masts, aerials, chimneys or smokestacks.
- H. Accessory Building Standards.** Accessory buildings, except as otherwise permitted by this Ordinance, shall require a building permit and shall be subject to the following regulations in all industrial zoning districts.
1. Where the accessory building is structurally attached to the principal building, it shall be subject to, and shall conform to, all regulations of this Ordinance applicable to the principal building.
 2. Accessory buildings shall not exceed 50 percent of the ground floor area of the principal building.
 3. No detached accessory building shall be located closer than 10 feet to any principal building, and may require greater separation when requested by the Fire Marshal.
 4. An accessory building may be connected to the principal building by a breezeway or other similar structure but shall not be considered as an attached accessory building, carport, or similar structure. Said breezeway shall not project nearer the side lot line than the minimum side yard required for the main building.
 5. Accessory buildings/structures shall be permanently affixed to the ground and shall not include mobile home, bus, travel trailer, RV, trailer, cooler, vehicle or freight container. Ground level storage units shall be exempt from the requirement to be permanently affixed and shall be allowed in industrial districts with appropriate screening as outlined in 4.6.8.D.

SEC. 4.8 SPECIAL PURPOSE DISTRICTS

4.8.1 Planned Unit Development (PUD)

- A.** The purpose and intent of the Planned Unit Development District are as follows:
1. Encourage and provide a means for effecting desirable development, redevelopment, rehabilitation and conservation within Warren County.
 2. Permit greater flexibility in design and permit planned mixture of types of uses, occupancy, tenure, types of housing, types of ownership and community facilities and promote the advantages of modern large scale site planning for community development.
 3. Provide for more useable and suitably located recreation facilities and other public and common facilities than would otherwise be provided under conventional land development procedures, but always with the intention of furthering the public health, safety, and general welfare.
 4. Promote the efficient use of land to facilitate a more economic arrangement of buildings, circulation systems, land use, and utilities.
 5. Preserve to the greatest extent possible the existing landscape features and urban amenities and to utilize such features in a harmonious fashion.
- B. Uses Permitted.** Uses shall be limited to those identified in the approved general development plan for the PUD.
- C. Development Standards.**
1. Any parcel proposed for development as a PUD shall have a minimum lot size of 5 acres.
 2. Any PUD shall be developed in accordance with the standards identified in the approved general development plan for the PUD.
 3. Any PUD development shall be in compliance with all adopted health, fire, and building codes.
 4. In some cases, off-premise signs may be used with a PUD (see Sec. 4.6.8.F.11). These signs may advertise businesses located elsewhere within the PUD. Size, height, and location of the signage shall be described in the approved Detailed Development Plan or special agreement and shall conform with Sec. 4.6.8.F.11. The Detailed Development Plan shall also include provisions for sign maintenance and easement dedication.

4.8.2 General Flood Plain District (F)

A. Land to Which Flood Plain Designation Applies. All lands determined to:

1. Be inundated by a storm event equal to a 100 year return period or included in the area inundated by the 100 year flood;
2. Be subject to inundation by directed runoff from short return period events; or
3. Contain an opening into the subterranean water channel, shall be subject to these regulations.

The originally designated areas shall include those areas shown on either the Flood Insurance Studies for the City of Bowling Green and Warren County prepared by the Federal Emergency Management Administration (FEMA) dated May 2, 2007 or as is from time to time amended and the Flood Hazard Boundary Maps (FB-4M) and Flood Insurance Rate Maps (FIRM) contained therein or U.S. Soil Conservation Services, Soils Maps of Warren County dated 1977 or as from time to time amended.

Nothing contained herein shall prohibit the application of these regulations to lands which can be certified to the Commission by a Kentucky registered professional engineer to lie within any area subject to periodic flooding, impaction by storm drainage or containing an opening into a subterranean water channel.

B. Warning and Disclaimer of Liability. The degree of flood protection required by this Ordinance is considered reasonable for regulatory purposes and is based on scientific and engineering consideration. Larger floods can and will occur on rare occasions. Flood heights may be increased by man-made or natural causes. This Section does not warrant, directly or indirectly, that areas outside the Flood Plain District or land uses permitted within such district will be free from flooding or flood damages. This Section shall not create liability on the part of the Cities of Bowling Green, Plum Springs, Oakland, Smiths Grove, Woodburn or Warren County or any officer or employee thereof for any flood damages that result from reliance on this article or any administrative decision lawfully made there under.

C. Maintenance of Property. This Section does not obligate the Cities of Woodburn, Plum Springs, Oakland, Smiths Grove, Bowling Green or County of Warren or any agencies or sub-agencies any assumption of maintenance of any area designated as a Flood Plain District. Nor does it assume any maintenance obligation for storm drainage systems approved by such cities and the City-County Planning Commission of Warren County.

D. Permitted Structures. No principal or accessory structures shall be permitted within any area designated as a part of a Flood Plain District. Structures located on lots partially included within the Flood Plain District shall be permitted provided they are located outside of the limits of the Flood Plain District and the first floor and basement floor are at least 1.5 feet above the regulatory flood-projection elevation and is utilized in conjunction with a

Article 4

Zoning Districts – Special Purpose

permitted use carried on within the adjacent district.

The area designated as Flood Plain District may be used to meet yard and setback requirements of adjoining districts for lots owned under single ownership.

E. Permitted Uses. The following open space uses shall be permitted provided they do not require structures or fill or cause obstruction of flood flows or restrict the capacity of the channel or floodways of any main stream, tributary, or any other drainage facility or structure or cause erosion and are used in conjunction with a permitted use carried on within an adjacent district on lots owned under single ownership.

1. **Agriculture Uses:** General farming, outdoor plant nurseries, sod farming, animal brooding and breeding, wild crop farming, apiary, crops, dairy, forestry, livestock, orchards, poultry, pasture, grazing, horticulture, viticulture and truck farming, detention basins, and ponds or lakes.
2. **Public Uses:** Arboretum or botanical garden, recreation uses, nursery including agriculture and florists, detention basins, ponds or lakes, and hiking and horseback riding trails, playgrounds both public and private.
3. **Commercial and Industrial Uses:** Private recreational uses, nursery including agriculture and florists, detention basins, ponds or lakes, hiking and horseback riding trails, playgrounds both public and private, and sales and storage of hay and straw loading areas.
4. **Residential Uses:** Lawns, play areas, and gardens.

F. Conditional and Accessory Uses. The following uses are conditionally permitted with the written approval of the Board of Adjustments and are used in conjunction with a permitted use carried on within an adjacent district on lots owned under single ownership.

1. **Agriculture Uses:** Cattle shed, stables, fur farms, natural gas and oil wells, hatcheries, kennels and dog pounds, and poultry farm.
2. **Public Uses:** Airplane beacons and markers, amphitheater and band shell, athletic fields and ball park (all types), camp grounds, circus or fair grounds, comfort stations, golf driving range and courses, natural gas and oil wells, tennis courts, tent show area, trap and skeet ranges, zoological gardens, marinas, boat rentals, docks, piers, wharfs and boat ramps.
3. **Commercial and Industrial Uses:** Amusement parks, amphitheater and band shell, athletic fields and ball parks (all types), camp grounds, country clubs, golf driving range and courses, natural gas and oil wells, gravel pits, kennels and dog pounds, mining and quarries, outdoor motion picture theaters, sand, stone and gravel extraction, processing, storage, quarrying, cutting, screening or

crushing, airport landing strips, railroads, street, bridges, utility transmission lines and pipelines.

G. Standards for All Uses in District (Permitted and Conditional)

1. **All Uses:** No fill (including fill for roads), deposit, obstruction, storage of materials or equipment, or other use may be allowed which, acting alone, or in combination with existing or future uses, would cause any decrease in the capacity of the floodway or would cause any increase in flood heights, cause erosion or obstruction of water course, natural drainage crevices, sinkholes, ditches and known subterranean water channels. Consideration of the effects of a proposed use shall be based on a reasonable assumption that there will be an equal degree of encroachment extending for a significant reach on both sides of the watercourse.

2. **Conditional Uses:** All floodway conditional uses shall be subject to the standards contained in paragraph A above and the following standards:
 - a. **Fill:**
 - (1) Any fill or material proposed to be deposited in the floodway must be shown to have some beneficial purpose and the amount thereof not greater than is necessary to achieve that purpose, nor will it cause any increase in the flood heights. These conditions must be demonstrated by a plan submitted by the owner and prepared by registered engineer showing the uses to which the filled land will be put and the final dimensions of the proposed fill or other materials and how such fill will be placed and compacted.

 - (2) Such a fill or other materials shall be protected against erosion by riprap, vegetation cover, or bulkheading.

 - b. **Storage of Material and Equipment:**
 - (1) The storage or processing of materials that, in time of flooding, are buoyant, flammable, explosive, or could be injurious to human, animal, or plant life is prohibited.

 - (2) Storage of other material or equipment may be allowed if not subject to major damage by floods and firmly anchored to prevent flotation or if readily removable from the area within the time available after flood warning.

Article 4

Zoning Districts – Special Purpose

c. Other General Standards:

- (1) Electrical, heating, ventilation, plumbing, air conditioning equipment, ductwork, and other service facilities shall be located at least 1.5 feet above the regulatory flood-projection elevation.
- (2) New and replacement water supply systems shall be designed to minimize or eliminate infiltration of flood waters into the system;
- (3) New and replacement sanitary sewage systems shall be designed to minimize or eliminate infiltration of flood waters into the system and discharges from the systems into flood waters;
- (4) On-site waste disposal systems shall be located outside the base flood elevation and constructed so as to avoid impairment to them or contamination from them during flooding.

SEC. 4.9 OVERLAY DISTRICTS

4.9.1 General

Where an overlay district and the underlying or base zoning district have different standards or regulations, the most restrictive standards or regulations pertaining to that land shall apply.

4.9.2 Urban Growth Overlay District (UG)

A. Purpose and Intent. The Urban Growth Overlay District is intended to implement focal point plans for growth areas, to promote innovative, attractive and efficient use of land, to encourage planned development and multi-modal transportation systems and to permit flexibility and creativity in the design of such planned development. The purpose of this ordinance shall include, but not be limited to the following:

1. To encourage and promote the public health, safety and general welfare of the citizens of the City and County, including the development and coordination of municipal growth and services.
2. To encourage originality, flexibility, innovation in site planning and development, and vehicular and pedestrian circulation, including the architecture, landscaping and graphic design of proposed developments in relation to the area as a whole.
3. To discourage monotonous, unsightly, and inharmonious developments, minimize discordant and unsightly surroundings and visual blight, and avoid inappropriate and poor quality design.
4. To promote orderly community growth, protect and enhance property values for the community as a whole and other environmental and aesthetic considerations which generally enhance rather than detract from community standards and values of the comfort and prosperity of the community and the preservation of its natural beauty and other natural resources, which are the proper concern of local government, and to promote and enhance construction and maintenance practices that will tend to enhance environmental and aesthetic quality for the community as a whole.

B. Description of the Area. The following areas are hereby designated an Urban Growth Overlay Districts requiring review from the Urban Growth Design Review Board:

1. **Cemetery Road Corridor (KY 234) see Exhibit C in Appendix A.**
2. **Lovers Lane Corridor (KY 880) see Exhibit C in Appendix A.**

Article 4

Zoning Districts – Overlay Districts

- C. Permitted Uses.** Except as prohibited in item D, below, uses permitted in each zoning district are those uses permitted in the underlying zoning district as enumerated in the Use Table in Sec. 5.1. This table employs broad use categories containing a variety of similar uses for each Zoning District. The use categories are described in Sec. 5.2, Use Categories, and Appendix B, which lists examples of uses (showing which use categories they fall into).
- D. Prohibited Uses.** The following uses are expressly prohibited in each Urban Growth Overlay District:

Cemetery Road Corridor (KY 234) see Exhibit C in Appendix A.

1. Adult entertainment establishments;
2. Night clubs, bars, and lounges which derive less than 50 percent of their income from food sales;
3. Outdoor storage of any type;
4. Self-storage or warehousing units;
5. Manufactured home and model home sales lots;
6. Retail Establishments that have outside display units for sale, including vehicles for sale;
7. Vehicle Repair or Vehicle Service Uses; and
8. Any Light or Heavy Industrial Uses.

Lovers Lane Corridor (KY 880) see Exhibit C in Appendix A.

1. Adult entertainment establishments;
2. Night clubs, bars, and lounges which derive less than 50 percent of their income from food sales;
3. Outdoor storage (Type 3 and Type 4);
4. Self-Storage Units;
5. Manufactured home and model home sales lots; and
6. All Heavy Industrial Uses, except Manufacturing and Warehousing.

- E. Development Standards - Cemetery Road (KY 234) Overlay District.** Buildings should reflect an individual design that has considered site location, conditions, and surrounding development. Building design should provide a sense of permanence and timelessness. High quality construction and materials should be used to ensure that buildings will not look dated or worn down over time. Building designs should reflect an individual style and form and not merely current trends. However, reliance on or use of standardized “corporate or franchise” style is strongly discouraged. For all developments within the overlay district, other than single-family residential or agriculture, the following technical standards shall apply:

1. **General Development Standards.** All building setbacks are measured from the right-of-way.

Article 4

Zoning Districts – Overlay Districts

- a. Minimum required lot size on sanitary sewer shall be one-half acre. Minimum required lot size on septic system shall be three acres.
- b. Minimum required front building setback abutting a local street shall be 30 feet.
- c. Minimum required rear building setback shall be 20 feet.
- d. Minimum required side building setback (not on corner lot) shall be 20 feet.
- e. Minimum side building setbacks for corner lots abutting a local street shall be 30 feet.
- f. Minimum front, side and rear building setbacks abutting a collector or arterial street shall be 50 feet.
- g. Minimum front, side and rear building setbacks abutting a single family residential district shall be 50 feet.
- h. Height limitation for structures shall be a maximum of three stories or 42 feet including mechanical penthouse and roof-top screened equipment.
- i. Maximum Usable Lot Area:
 - (1) The maximum surface land area of the building shall not exceed 30 percent of the total lot area. Parking areas, open courts and other open space uses shall not be included in building area.
 - (2) For all uses permitted within this overlay district, no more than 70 percent of the total surface land area of the lot shall be improved with buildings, structures, parking and loading areas, streets, driveways or roadways.
- j. Maximum building size. Within the Cemetery Road Overlay District, the building footprint of any building shall conform to the following:
 - (1) All one-story buildings shall not exceed 20,000 sq. ft.
 - (2) All two-story buildings shall not exceed a first floor footprint of 15,000 sq. ft.; total gross area shall not exceed 30,000 sq. ft.

Article 4

Zoning Districts – Overlay Districts

- (3) All three-story buildings shall not exceed a first floor footprint of 10,000 sq. ft.; total gross area shall not exceed 30,000 sq. ft.
- (4) Any building served by on-site septic systems shall not exceed 6000 sq. ft. in size.
- (5) If the Design Review Board determines that the proposed building and development is compatible in bulk and scale to the adjoining properties, these maximum building limits may be increased (on sewer only). For every additional square foot of building space allowed beyond the limits outlined in this section, the property owner must dedicate an additional two square feet of greenspace within this proposed site. However, under no circumstances shall a proposed development exceed the limitations outlined in Article 4.9.2.E.i. above.

k. Green space area.

- (1) All sites shall be developed with not less than 20 percent of the total area with green space. Green space shall be landscaped with trees, green shrubbery, grass and/or other plantings exclusive of any plantings or landscaping treatment in parking lot islands measuring less than 200 square feet. Such green space shall be located on the site to provide the maximum visibility of the green space to surrounding properties and public streets. No more than 50 percent of the required green space may be located within drainage facilities.
- (2) All parking areas located adjacent to an arterial or collector road right-of-way shall be screened by a permanent landscaped berm or hedge, at least 30 to 36 inches in height at maturity (and 18-24 inches in height at planting), measured at the finished grade of the top of curb of the parking area. Acceptable hedge species shall be limited to those plants contained on the Master Plant List maintained by the City-County Planning Commission. At least 50 percent of the required shrub material shall be of an evergreen species.

- 2. **Landscape Buffer Standards.** All adjoining non-residential property located within the Overlay District shall be required to provide a landscape plan. Also, in locations where

Article 4

Zoning Districts – Overlay Districts

property zoned non-residential and residential are adjacent (either immediately adjacent to or across a public right-of-way), a landscape plan will be required with the development of either site. This shall not apply to the development of one and two family homes. When a site development plan is submitted for the review and consideration of the Design Review Board, special care shall be taken to minimize the effects on the adjacent residential area.

- a. The following shall be considered minimum standards for the development of landscape plans for required buffers/screens and interior vehicle use areas:
 - (1) A minimum 25-foot buffer strip shall be required on the outer perimeter of the non-residential building lot abutting the property currently zoned for residential or agricultural use or development. No travelways, parking areas, structures or storage of material shall be allowed within the buffer strip.
 - (2) A minimum 10 foot buffer strip shall be required on each lot between all other parcels regardless of zoning or use.
 - (3) All buffer yards as required within the overlay district shall be planted to the following minimums. The quantities listed are to be an average of each entire buffer yard as required.
- b. For screening of parking or vehicle use areas adjacent to any right-of-way, all areas shall be planted at the minimum average rate of one shade tree and 12 shrubs for each 400 square feet of buffer provided. Smaller ornamental trees may be used in place of the shade tree at a ratio of three ornamental trees for each shade tree for up to one-half the required shade trees. One-half of all shrub material shall be of an evergreen species. Shade trees planted to comply with this section shall also be counted towards the required street tree planting as stated in other sections of this overlay district. All plants shall come from the Master Plant list with exceptions being allowed only in writing from the City-County Landscape Architect.
- c. For interior parking lot landscaping, a minimum of five percent of the area parking or vehicle use area must be used for landscaping. The minimum contiguous area to be counted towards the requirements shall be 75 square feet. All landscape islands shall have a minimum width of six feet in any direction. The maximum distance between landscape islands shall

Article 4

Zoning Districts – Overlay Districts

be 120 feet as measured from face of curb. A minimum of one tree shall be planted for each 200 square feet of required landscaped area, with the remaining areas to be planted in shrubs or non-turf ground cover. Landscape areas within 10 feet of a building shall be considered foundation planting and not be counted towards the minimum requirements of this article.

- d. For screening of parking or vehicle use areas adjacent to a common property line, and buffers between incompatible land uses, all areas shall be planted at a rate of one shade tree, two evergreen trees and 10 shrubs for each 400 square feet of buffer provided. Smaller ornamental trees may be used in place of the shade trees at a ratio of three ornamental trees for each shade tree for up to one-half the required shade trees.
- e. The minimum size at planting of required plants shall be as noted:

TYPE	Min. Size
Shade and ornamental trees	1-3/4" caliper
Evergreens	6' height
Shrub material	18-24" height

- f. All plants material to be installed as required shall conform to the standards of the American Association of Nurserymen and shall have passed any inspection required under State regulations. All plants must be maintained in a healthy manner and replaced during the next appropriate planting season. All dead plant material shall be removed within 45 days. Plant material placement shall comply with all sight distance requirements.
- g. In instances where a masonry or board on board fence is to be provided, the required shrub and evergreen planting requirements may be reduced by 50 percent. Shade trees shall still be required at the rates as above.
- h. For sites that contain less than 50 parking spaces, landscape plans shall be prepared for all site development within the overlay district and may be submitted by either an architect, landscape architect, engineer or surveyor, licensed to practice their profession in the State of Kentucky, or a Kentucky

Article 4

Zoning Districts – Overlay Districts

certified nurserymen. For sites with over 50 parking spaces the plan must be submitted by a landscape architect licensed to practice in the State of Kentucky.

- i. All submitted landscape plans shall include the following: Plan drawn to scale with all easements shown and labeled, building footprint, parking, travelways, topography at a minimum of two-foot contours, plant schedule including botanic and common names, size, quantity and condition, and the seal and signature of the person submitting the landscape plan. A minimum of four copies shall be required to be submitted, additional copies may be requested by the Design Review Board.
 - j. The planting provisions of this section may be varied or reduced if the proposed plan provides for unique and innovative landscaping treatment or physical features that, in the opinion of the Design Review Board, meet the intent and purpose of this section. In no case shall the buffer width be reduced when adjacent to the interstate or Kentucky 234. Existing vegetation may be used to satisfy the requirements of this section only when the existing vegetation is on the lot under review. The submission of an existing vegetation/tree preservation plan to the City-County Landscape Architect and the Design Review Board for review shall be required.
 - k. Prior to the issuance of a building permit, a security acceptable to the Planning Commission shall be required to ensure completion of all landscaping/screening provisions as outlined in the plan approved by the Design Review Board. The security shall be posted in an amount equal to 115 percent of the total estimated costs of the materials and installation of the improvements. Upon the issuance of a certificate of occupancy for the building, a maintenance bond or similar form of security acceptable to the Planning Commission shall be required for a period of one year to ensure that the vegetation remains as a living and viable screen.
3. **Off-Street Parking and Loading.** The number, size and design of all parking spaces, internal access ways and loading spaces for all land uses (other than single family detached) within the designated overlay district shall comply with the following requirements listed below:
- a. All parking shall be off-street in paved, landscaped parking areas.

Article 4

Zoning Districts – Overlay Districts

- b. Off-street loading or service areas shall not face a public right-of-way and shall be at least 30 feet from any right-of-way. Any loading or service area adjacent to residential property shall be screened with a masonry or wood fence, and the required landscape buffer planting.
- c. All non-residential buildings less than 10,000 sq. ft. shall be required to have at least one service or loading/unloading space measuring a minimum of 12 feet by 24 feet. All non-residential buildings of more than 10,000 sq. ft. will be required to have a minimum of two service or loading spaces.
- d. Within the bounds of this Overlay District, this Ordinance shall strictly comply with the access limitations of the Kentucky Transportation Cabinet for KY 234. These limitations are as follows:
 - (1) KY 234 is a fully controlled access facility from the intersection of KY 234 and Briteway Drive to the intersection of KY 234 with KY 2158 (Cumberland Trace). Within these limits, access to KY 234 is limited to the intersection of KY 234 with KY 880/Ewing Ford Road, the intersection of KY 234 with I-65 Southbound Ramps, and the intersection of KY 234 with I-65 Northbound Ramps.
 - (2) KY 234 is an “access by permit” facility from the intersection of KY 234 with KY 2158 (Cumberland Trace) to the end of the KY 234 construction project at a point west of the bridge over Drakes Creek. Within these limits, access to KY 234 is granted through the commercial/ residential entrance permit process under the jurisdiction of the Kentucky Transportation Cabinet.
- e. In office and commercial/retail developments, at least 50 percent of the required parking shall be to the rear of the front building face.
- f. Parking setbacks shall conform to the following standards:
 - (1) When adjacent to compatible uses, the parking setback shall be 10 feet from the property line.
 - (2) When adjacent to incompatible uses, the parking setback shall be 25 feet.

Article 4

Zoning Districts – Overlay Districts

- (3) When adjacent to a public right-of-way or public access easement, the parking setback shall be 10 feet from the right-of-way.
 - g. Traffic circulation in office, commercial, and multi-family developments should be designed so as to direct traffic away from single family residential streets.
 - h. Joint driveways in commercial and office districts are desirable whenever possible in order to minimize the number of access points to streets.
- 4. **Lighting.** Adequate outside lighting shall be provided to ensure safe movement of persons and vehicles and for security purposes. At the same time, such lighting shall be directed downward and arranged so as to minimize glare and reflection on adjacent residential properties and public streets. The Design Review Board may require the submission of a lighting plan by a qualified professional engineer to ensure that the illumination of outside lighting as designed and installed does not exceed one-half (.5) foot candles measured at the property line of abutting property zoned for residential use or development. All freestanding light poles and fixtures shall be black. Suggested lighting styles are as follows:
 - a. Teardrop with optic cutoffs
 - b. Lantern with prismatic fixtures
 - c. Bollards for pedestrian access.
- 5. **Fence Material.** All proposed fences within the Overlay District (except for single family residential and agricultural lots) must be reviewed and approved by the Design Review Board prior to the issuance of a building permit. Acceptable fence material shall be wood, masonry, stone, vinyl/PVC, tubular steel or aluminum, agricultural fence (for agricultural purposes) and decorative wrought iron. All chain-link fences are prohibited within the Overlay District (except on existing individual single family residential lots). All fences shall be at least four feet in height and not higher than eight feet in height. Suggested fence styles are as follows:
 - a. 4-rail plank
 - b. Masonry columns with wood panels
 - c. Decorative masonry
 - d. Random-faced stone
 - e. Decorative metal
 - f. Agricultural fence for agricultural purposes only.

Article 4

Zoning Districts – Overlay Districts

6. **Signs.** The visual transfer of business advertising and other public information through the use of external signs in this zoning district shall comply with the following sign requirements. All signs, excluding traffic signs, must be approved by the Design Review Board and shall conform to the following uniform sign standards:
- a. Materials, colors, and shades of proposed signs shall be compatible with the related buildings on the property and must be approved by the Design Review Board. All completed signs must have a high quality professional appearance. Sign materials shall be limited to high quality construction materials such as:
 - (1) Stone, brick, or decorative block
 - (2) Finished wood (painted or stained)
 - (3) Finished metal
 - (4) High quality plastic
 - b. Signage shall be limited to one (1) freestanding for each roadway frontage and one (1) wall sign. In cases where there are multiple tenants, each tenant within the property shall be allowed one wall sign.
 - c. Freestanding signs shall be ground-mounted, monument style with proper landscaping and be set back from the road sight triangle as to prohibit obstruction of view.
 - d. Freestanding signs shall not exceed 5 feet in total height (from the grade to the top of the sign face) and 75 square feet per side, and shall be located in a manner that will not create a traffic hazard. Total freestanding structure shall not exceed 7 feet in height.
 - e. External lighting of monument signs shall be concealed and ground-mounted.
 - f. Freestanding pole signs (excluding flag poles) are prohibited. Maximum number of flag poles per site shall be three (3) with a maximum pole height of 40 feet, with the maximum area of each flag not to exceed 50 square feet. Only government, or other official designated flags of an institution or business are allowed.
 - g. Changeable letter boards may make up no more than 20 percent of the area of a freestanding sign. Letters/numbers shall be no more than 12 inches in height.

Article 4

Zoning Districts – Overlay Districts

- h. Signage in planned shopping centers shall be limited to one ground-mounted, monument style sign for each roadway frontage. Each tenant in the shopping center shall be allowed one wall sign per frontage with a maximum of two signs.

- i. Wall signs, including window and awning lettering, are permitted on a limited basis within the Overlay District. All wall signs shall not extend beyond the roof line. The lighting of wall-mounted signs shall be mounted on the building. The limitations for each street frontage are as follows:
 - (1) Wall signs for buildings or tenants having less than 2,500 square feet of gross leasable area shall not exceed 25 square feet.
 - (2) Wall signs for buildings or tenants having more than 2,500 square feet, but less than 7,500 sq. ft. shall not exceed 40 square feet.
 - (3) Wall signs for buildings or tenants having more than 7,500 square feet shall not exceed 100 square feet.

- j. Internally-lit single frame (or box) signs containing a logo or trademark are permitted on a limited basis within the Overlay District. These limitations are listed below:
 - (1) Freestanding internally-lit signs shall not exceed 12 square feet and shall be considered as part of the allowable sign as outlined in this Section.
 - (2) Internally-lit wall signs shall not exceed 20 square feet, and shall be considered as part of the allowable sign area outlined in this Section.

- k. Wall mounted internally-lit individual letters are permitted on a limited basis within the Overlay District and shall be considered part of the allowable wall sign area outlined in 4.9.2.D.6.i. above. These additional limitations are listed below:
 - (1) Buildings or tenants having less than 2,500 square feet of gross leasable area shall not exceed 25 square feet of total outlined sign area. No letters shall exceed 24 inches in height or width.

Article 4

Zoning Districts – Overlay Districts

- (2) Buildings and tenants having more than 2,500 gross leasable area (GLA) but less than 7,500 GLA shall not exceed 40 square feet of total outlined sign area. No letters shall exceed 30 inches in height or width.
- (3) Buildings and tenants having more than 7,500 GLA shall not exceed 75 square feet of total outlined sign area. No letters shall exceed 36 inches in height or width.
- l. Illumination of signs shall be directed away from all traffic and from all adjoining residential areas. The intensity of the light shall not exceed 15 footcandles at any point on the sign face.
- m. Vending machines must be contained inside the principal building and shall not be allowed in direct view from the parking or right-of-way areas.
- n. Billboards and portable signs shall be prohibited. Flashing signs and roof mounted signs shall be prohibited.
- o. All signage shall be subject to the sign regulations outlined in the Zoning Ordinance/Resolution for Warren County or any amendments thereto. In instances where the two ordinances do not agree, the more restrictive of the two shall apply.

7. Traffic Design

- a. All internal streets, drives, travelways, sidewalks/trails, parking and loading areas shall be designed for safe and efficient movement of vehicles and pedestrians. Projects to be developed within the Overlay District and contiguous to the Greenbelt shall be required to provide direct pedestrian access, separate from any vehicle entry, to the Greenbelt trail. Developments that are not contiguous to the Greenbelt trail shall provide either a sidewalk or trail that will allow for the movement of pedestrians to the Greenbelt trail, separate from the street system. If the trail or sidewalk is located on the site being developed between any parking or travelway and a property line, the trail or sidewalk shall be in addition to the required landscape buffer. All development shall allow for inter-parcel access of vehicles (two-way travelway) and pedestrians (via sidewalk or trail) to adjacent property. Inter-parcel access points shall be located behind the front building setback line.

Article 4

Zoning Districts – Overlay Districts

- b. **Design Standards.** All streets, drives, and parking and loading areas shall be a minimum of 24 feet in width for two-way traffic, and 12 feet for one-way traffic. The maximum slope shall not exceed six percent in any direction. All streets, drives, and travelways above grade shall be constructed with curb and gutter. The perimeter parking lots and internal islands shall have extruded curbs. Intersections shall be at 90 degrees. With the exception of designated passenger drop-off areas and loading and unloading spaces, the minimum distance from any travelway or parking space to a building shall be 10 feet. For all pedestrian circulation, the minimum sidewalk shall be five feet in width and any asphalt trail shall be at least 10 feet in width. The maximum slope shall not exceed six (6) percent and shall comply with all rules within the Americans with Disabilities Act (ADA).

- 8. **Erosion Control and Storm Water Management.** The control of erosion during development and the design of drainage systems suitable to handle storm water runoff after the site is developed shall comply with the requirements of the subdivision regulations of the Planning Commission. All erosion control devices must be in place prior to beginning construction. A detailed storm water management plan as specified by the Planning Commission Engineer shall be required for all new development.

- 9. **Utility Provisions.** All developments shall be served with minimum public sanitary sewer and water lines of eight inches and six inches respectively, with actual sizing and other technical requirements for connection to public utilities subject to approval by the Planning Commission Engineer. All electric, telephone, cable and similar service lines and other wiring shall be installed underground, and there shall be no new overhead wiring in any development.

- 10. **Exterior Treatment.** Any proposed land use or development approved by the Design Review Board shall be designed and constructed of materials so as to be architecturally compatible with the architectural character of the general area.
 - a. All building exteriors shall be finished with one or more of the following materials:
 - (1) architectural masonry units, including brick, decorative concrete masonry units, and special surface units (plain-laid concrete or cinder block will not be allowed);
 - (2) natural stone;

Article 4

Zoning Districts – Overlay Districts

- (3) precast and poured-in-place concrete; EFIS or Dryvit (not to exceed 50% of the total exterior)with approval of surface treatment;
 - (4) glass, glass curtain, glass surface units;
 - (5) wood clapboard, trim;
 - (6) The use of vinyl or metal shall be limited to only fascia, soffit, and other minor trim uses within the district.
- b. New single family residential units may also utilize vinyl/aluminum siding, up to 20 percent of the exterior.
 - c. Finished materials shall extend around all sides of the building.
 - d. No more than two principal colors shall be used on the building face. Accent or secondary colors shall be limited to a maximum of three additional colors and shall not cover more than 10 percent of the total building face. Use of bright or garish colors as the dominant color for the wall or roof surfaces is prohibited.
 - e. All non-residential buildings located along KY 234 shall be designed in such a way as to appear to face the highway, regardless of the location of the driveway access and parking. All building walls facing KY 234 shall have windows, doors, or other articulated openings representing a minimum of 20 percent of the surface areas of said wall. Building components such as windows, doors, eaves, and parapet walls should have good proportion and relationship to one another. All building walls facing any other right-of-way shall have some form of articulated relief or change in direction, every 30 feet.
 - f. Roof-mounted utilities and mechanical equipment should be screened from view by roof design, parapet walls, fencing, or other screening method to a height equal to or greater than the height of the equipment.

11. Solid Waste.

- a. Solid waste storage and disposal areas shall be screened from public view and shall be maintained in compliance with the county health department regulations.

Article 4

Zoning Districts – Overlay Districts

- b. Solid waste storage and disposal areas shall be enclosed in an eight (8) foot high solid structure, of the same material as that of the principal building.
 - 12. **Screening of Equipment and Outside Storage.** Ground and roof level electrical transformers, heat and air conditioning equipment and similar facilities shall be screened from public view.
 - 13. **Noise.** The intensity level of sound from the activities on the commercial site measured at the property line of abutting property zoned for residential use or development shall not at any time exceed 70 decibels. In instances where the Design Review Board determines that a new commercial site may create objectionable noise or a nuisance to any adjacent property, additional buffers or other physical features shall be required to mitigate the noise.
 - 14. **Redevelopment of Existing Site.** It is recognized that certain nonresidential properties in the overlay district were developed prior to incorporation and/or adoption of technical and development standards for the district. When an existing nonresidential site is redeveloped, the site shall be brought into conformance with the technical and development standards of this division to the greatest extent feasible or possible as determined by the Design Review Board. For the purposes of this section, redevelopment shall include any proposed expansion, addition, or facade change to an existing building, structure, or parking facility.
- F. Development Standards - Lovers Lane (KY 880) Overlay District.** Buildings should reflect an individual design that has considered site location, conditions, and surrounding development. Building design should provide a sense of permanence and timelessness. High quality construction and materials should be used to ensure that buildings will not look dated or worn down over time. Building designs should reflect an individual style and form and not merely current trends. However, reliance on or use of standardized “corporate or franchise” style is strongly discouraged. For all developments within the overlay district, other than single-family residential or agriculture, the following technical standards shall apply:
- 1. **General Development Standards.** All building setbacks are measured from the right-of-way.
 - a. Minimum required lot size on sanitary sewer shall be one-half acre. Minimum required lot size on septic system shall be three acres.
 - b. Minimum required front building setback abutting a local street shall be 30 feet.

Article 4

Zoning Districts – Overlay Districts

- c. Minimum required rear building setback shall be 20 feet.
- d. Minimum required side building setback (not on corner lot) shall be 20 feet.
- e. Minimum side building setbacks for corner lots abutting a local street shall be 30 feet.
- f. Minimum front building setbacks abutting Lovers Lane (KY880) shall be 50 feet.
- g. Minimum front, side and rear building setbacks abutting an existing single family residential district shall be 50 feet.
- h. Minimum building setbacks abutting Interstate 65 shall be 50 feet.
- i. A portion of the Airport Overlay District is within this Urban Growth Overlay District. The Airport Overlay District outlines the area within proximity of the Bowling Green-Warren County Airport that is under the jurisdiction of the Kentucky Airport Zoning Commission (KAZC) (see Exhibit F in Appendix A). The underlying zoning restrictions, including height requirements, are governed by this ordinance; however, there may be additional restrictions on development in this area placed by the KAZC.
- j. Maximum usable lot area.
 - (1) The maximum surface land area of the building shall not exceed 50 percent of the total lot area. Parking areas, open courts and other open space uses shall not be included in building area.
 - (2) For all uses permitted within this overlay district, no more than 70 percent of the total surface land area of the lot shall be improved with buildings, structures, parking and loading areas, streets, driveways or roadways.
- k. Green space area.
 - (1) All sites shall be developed with not less than 20 percent of the total area with green space. Green space shall be landscaped with trees, green shrubbery, grass and/or other plantings exclusive of any plantings or landscaping treatment in parking lot islands measuring less than 200 square feet. Such green space shall

Article 4

Zoning Districts – Overlay Districts

be located on the site to provide the maximum visibility of the green space to surrounding properties and public streets. No more than 50 percent of the required green space may be located within drainage facilities.

2. **Landscape Buffer Standards.** All adjoining non-residential property located within the Overlay District shall be required to provide a landscape plan. Also, in locations where property zoned non-residential and residential are adjacent (either immediately adjacent to or across a public right-of-way), a landscape plan will be required with the development of either site. This shall not apply to the development of one and two family homes. When a site development plan is submitted for the review and consideration of the Design Review Board, special care shall be taken to minimize the effects on the adjacent residential area.
 - a. The following shall be considered minimum standards for the development of landscape plans for required buffers/screens and interior vehicle use areas:
 - (1) A minimum 25-foot buffer strip shall be required on the outer perimeter of the non-residential building lot abutting the property currently zoned for residential or agricultural use or development. No travelways, vehicle use areas (VUA), outdoor display areas, structures or storage of material shall be allowed within the buffer strip.
 - (2) A minimum 20 foot buffer strip shall be required along Ky 880 (Lovers Lane).
 - (3) A minimum 10 foot buffer strip shall be required on each lot between all other parcels regardless of zoning or use.
 - (4) All vehicle use areas (VUA) shall be required to provide a minimum of five percent (5%) of the interior of the VUA in landscape islands, as defined in Article 4.6.8.D. of this ordinance.
 - (5) All allowable outdoor display areas shall comply with the buffer width requirements, as described above, and be setback a minimum of twenty (20) feet from any right-of-way. Screening of any outdoor display area(s) from a common property line or right-of-way shall be planted to the minimum buffer requirements for incompatible land uses as outlined in Article 4.6.8.D of this ordinance.

Article 4

Zoning Districts – Overlay Districts

- (6) All buffer yards as required within the overlay district shall be planted according to the requirements listed in 4.6.8 D.
 - b. Prior to the issuance of a building permit, a security acceptable to the Planning Commission shall be required to ensure completion of all landscaping/screening provisions as outlined in the plan approved by the Design Review Board. The security shall be posted in an amount equal to 115 percent of the total estimated costs of the materials and installation of the improvements. Upon the issuance of a certificate of occupancy for the building, a maintenance bond or similar form of security acceptable to the Planning Commission shall be required for a period of one year to ensure that the vegetation remains as a living and viable screen.
- 3. **Access Limitations.**
 - a. Within the bounds of this Overlay District, this Ordinance shall strictly comply with the access limitations of the Kentucky Transportation Cabinet for KY 880. In addition, the following access requirements along the Lovers Lane are as follows:
 - (1) KY 880 is an “access by permit” facility and access shall comply with the City of Bowling Green’s adopted Traffic Access Management Guidelines.
 - b. Joint driveways in commercial and office districts are desirable whenever possible in order to minimize the number of access points to streets.
- 4. **Lighting.** Adequate outside lighting shall be provided to ensure safe movement of persons and vehicles and for security purposes. At the same time, such lighting shall be directed downward and arranged so as to minimize glare and reflection on adjacent residential properties and public streets. The Design Review Board may require the submission of a lighting plan by a qualified professional engineer to ensure that the illumination of outside lighting as designed and installed does not exceed one-half (.5) foot candles measured at the property line of abutting property zoned for residential use or development. All freestanding light poles and fixtures shall be black. Suggested lighting styles are as follows:
 - a. Teardrop with optic cutoffs;
 - b. Lantern with prismatic fixtures;

Article 4

Zoning Districts – Overlay Districts

- c. Bollards for pedestrian access.

- 5. **Fence Material.** All proposed fences within the Overlay District (except for single family residential and agricultural lots) must be reviewed and approved by the Design Review Board prior to the issuance of a building permit. Acceptable fence material shall be wood, masonry, stone, vinyl/PVC, tubular steel or aluminum, agricultural fence (for agricultural purposes) and decorative wrought iron. All chain-link fences are prohibited within the Overlay District (except on existing individual single family residential lots). All fences shall be at least four feet in height and not higher than eight feet in height. Suggested fence styles are as follows:
 - a. 4-rail plank
 - b. Masonry columns with wood panels
 - c. Decorative masonry
 - d. Random-faced stone
 - e. Decorative metal
 - f. Agricultural fence for agricultural purposes only.

- 6. **Signs.** The visual transfer of business advertising and other public information through the use of external signs in this zoning district shall comply with the following sign requirements. All signs, excluding traffic signs, must be approved by the Design Review Board and shall conform to the following uniform sign standards:
 - a. Materials, colors, and shades of proposed signs shall be compatible with the related buildings on the property and must be approved by the Design Review Board. All completed signs must have a high quality professional appearance. Sign materials shall be limited to high quality construction materials such as:
 - (1) Stone, brick, or decorative block
 - (2) Finished wood (painted or stained)
 - (3) Finished metal
 - (4) High quality plastic

 - b. Signage shall be limited to one (1) freestanding for each roadway frontage and one (1) wall sign. In cases where there are multiple tenants, each tenant within the property shall be allowed one wall sign.

 - c. Freestanding signs shall be ground-mounted, monument style with proper landscaping and be set back from the road sight triangle as to prohibit obstruction of view.

 - d. Freestanding signs shall not exceed 5 feet in total height (from the grade to the top of the sign face) and 75 square feet per side, and shall be located in a

Article 4

Zoning Districts – Overlay Districts

manner that will not create a traffic hazard. Total freestanding structure shall not exceed 7 feet in height.

- e. All wall signs shall not exceed a maximum area of 100 sf or 10% of Facade, which-ever is greater.
 - f. External lighting of monument signs shall be concealed and ground-mounted.
 - g. Freestanding pole signs (excluding flag poles) are prohibited. Maximum number of flag poles per site shall be three (3) with a maximum pole height of 40 feet, with the maximum area of each flag not to exceed 50 square feet. Only government, or other official designated flags of an institution or business are allowed.
 - h. Changeable letter boards may make up no more than 20 percent of the area of a freestanding sign. Letters/numbers shall be no more than 12 inches in height.
 - i. Signage in planned shopping centers shall be limited to one ground-mounted, monument style sign for each roadway frontage. Each tenant in the shopping center shall be allowed one wall sign per frontage with a maximum of two signs.
 - j. Illumination of signs shall be directed away from all traffic and from all adjoining residential areas. The intensity of the light shall not exceed 1.5 footcandles at any point on the sign face.
 - k. Billboards and portable signs shall be prohibited. Flashing signs and roof mounted signs shall be prohibited.
 - l. All signage shall be subject to the sign regulations outlined in the Zoning Ordinance/Resolution for Warren County or any amendments thereto. In instances where the two ordinances do not agree, the more restrictive of the two shall apply.
7. **Traffic Design.** All internal streets, drives, travelways, sidewalks/trails, parking and loading areas shall be designed for safe and efficient movement of vehicles and pedestrians. Projects to be developed within the Overlay District and contiguous to the Greenbelt shall be required to provide direct pedestrian access, separate from any vehicle entry, to the Greenbelt trail. Developments that are not contiguous to the Greenbelt trail shall provide either a sidewalk or trail that will allow for the movement of pedestrians to the Greenbelt trail,

Article 4

Zoning Districts – Overlay Districts

separate from the street system. All development shall allow for inter-parcel access of vehicles (two-way travelway) and pedestrians (via sidewalk or trail) to adjacent property. Inter-parcel access points shall be located behind the front building setback line.

8. **Erosion Control and Storm Water Management.** The control of erosion during development and the design of drainage systems suitable to handle storm water runoff after the site is developed shall comply with the requirements of the subdivision regulations of the Planning Commission. All erosion control devices must be in place prior to beginning construction. A detailed storm water management plan as specified by the Planning Commission Engineer shall be required for all new development.

9. **Utility Provisions.** All developments shall be served with minimum public sanitary sewer and water lines of eight inches and six inches respectively, with actual sizing and other technical requirements for connection to public utilities subject to approval by the Planning Commission Engineer. All electric, telephone, cable and similar service lines and other wiring shall be installed underground, and there shall be no new overhead wiring in any development.

10. **Exterior Treatment.** Any proposed land use or development approved by the Design Review Board shall be designed and constructed of materials so as to be architecturally compatible with the architectural character of the general area.
 - a. All building exteriors shall be finished with one or more of the following materials.
 - (1) architectural masonry units, including brick, decorative concrete masonry units, and special surface units (plain-laid concrete or cinder block will not be allowed);
 - (2) natural stone;
 - (3) precast and poured-in-place concrete; EFIS or Dryvit (not to exceed 50% of the total exterior) with approval of surface treatment;
 - (4) glass, glass curtain, glass surface units;
 - (5) wood clapboard, trim;
 - (6) The use of vinyl or metal shall be limited to only fascia, soffit, and other minor trim uses within 500 feet of KY 880 (Lovers Lane). The Design Review Board (DRB) may approve the use of alternative building materials on public,

Article 4

Zoning Districts – Overlay Districts

institutional or industrial buildings outside of the 500 foot area, if compatible with the adjoining properties.

- b. Finished materials shall extend around all sides of the building.
 - c. All non-residential buildings located along KY 880 shall be designed in such a way as to appear to face the roadway, regardless of the location of the driveway access and parking.
 - d. Roof-mounted utilities and mechanical equipment should be screened from view by roof design, parapet walls, fencing, or other screening method to a height equal to or greater than the height of the equipment.
11. **Screening of Equipment and Outside Storage.** Ground and roof level electrical transformers, heat and air conditioning equipment and similar facilities shall be screened from public view.
12. **Redevelopment of Existing Site.** It is recognized that certain nonresidential properties in the overlay district were developed prior to incorporation and/or adoption of technical and development standards for the district. When an existing nonresidential site is redeveloped as defined in Article 6, the site shall be brought into conformance with the technical and development standards of this district to the greatest extent feasible or possible as determined by the Design Review Board. All new signage shall conform to the requirements of item 4.9.2 E 6, (Signs).

4.9.3 Local Historic District, Local Historic Site (H) or Conservation District (C)

These areas are established to maintain and preserve the unique historic and architectural characteristics of areas and buildings having special or distinctive features or a special historic, architectural, aesthetic or cultural interest and value to the community, state and nation; to promote the use of these areas and buildings thus strengthening the economy of the community and enhancing its attractions to residents, visitors and tourists; to promote the educational, cultural and general welfare of the people; to stabilize and improve property values in historic districts and in the community as a whole; and to foster civic pride in the value of notable accomplishments of the past and to enhance the visual and aesthetic character, diversity and interest of the community. (See Exhibit D in Appendix A).

Article 4

Zoning Districts – Overlay Districts

4.9.4 University District (UD)

- A. Purpose.** The University District provides for a planned mix of residential dwelling types and other selected uses which are related to and which are located in close proximity to the main campus of Western Kentucky University. (See Exhibit E in Appendix A).
- B. Development Standards.**
1. **External Appearance.** When such use is located in any residential or public district, the external appearance of the structure shall be in the form and character of a single-family, detached dwelling.
 2. **Off-Street Parking.**
 - a. Two off-street parking spaces shall be provided for each three occupant beds, plus one space per each employee and counselor or advisor. The total number of spaces required shall not exceed a maximum number of 20 spaces or result in a greater percentage of lot coverage than is allowed by the district regulations as modified below. Additional spaces may be permitted as long as the impervious surface for the total lot area does not exceed that which is allowed by the district regulations. Calculations will be based on Kentucky Building Code Occupancy load requirements.
 - b. All parking areas shall be located either to the rear or to the side of the residence. No off-street parking shall be permitted in front yards.
 - c. All parking areas shall be paved and constructed so as to direct stormwater runoff to the appropriate drainage facility.
 3. **Open Space.** Total impervious surface, including buildings and required parking, for the underlying zones included in the University District shall not exceed the following ratio to open space:

District	Open Space
RS-1 (Single Family Residential)	50% Coverage/50% Open Space
RM-2, RM-3, RM-4 (Multi-Family Residential)	75% Coverage/25% Open Space
Residential Uses in the NB district	75% Coverage/25% Open Space
Residential Uses in the GB district	75% Coverage/25% Open Space

Article 4

Zoning Districts – Overlay Districts

4. Signs

- a. Identifications signs shall have a setback of 20 feet from the edge of pavement. Signs in the University District shall be for identity purposes only. The identification signs may be illuminated, shall be of low wattage, and shall not exceed 0.5 foot candles measured five feet above grade plane and 20 feet from the sign.
- b. Temporary signs such as: Banners, pennants, posters, flags (excluding government, political subdivision, or other official designated flags of an institution or business), fixed balloons, or similar devices shall be permitted if the devices are solely affixed to a window or the principal facade of the building and does not extend above the roof line. Banners, without advertising or commercial logos, and rush, homecoming, and other special activity decorations shall be considered temporary, on-premise signs and shall be permitted for a time period not to exceed 30 days.
- c. All permitted signs shall also comply with all the applicable Sign Development Standards in Section 4.6.8.F.

4.9.5 Rural Village Overlay District (V)

- A. Purpose and Intent.** The purpose of the Rural Village Overlay District is to provide for the continued vitality of the existing commercial and residential mixed use areas found in the smaller rural agricultural centers throughout Warren County. The rural village brings a sense of community and identification to the surrounding rural areas with an emphasis on providing essential goods and services to rural residents, but are not intended as employment designations for urban residents.
- B. Geographic Locations.**
 - 1. City of Smiths Grove
 - 2. City of Oakland
 - 3. City of Woodburn
- C. Permitted Principal Uses.**
 - 1. Uses permitted in the underlying zoning districts existing upon the adoption of this ordinance.
 - 2. Uses permitted in the Agricultural (A) zoning district, unless otherwise prohibited by City Ordinance.

Article 4

Zoning Districts – Overlay Districts

3. Residential uses permitted in the following zoning districts:
 - a. Residential Estate (R-E);
 - b. Single Family Residential (RS-1);
 - c. Two-Family Residential (RM-2); and,
 - d. Townhouse/ Multi-family Residential (RM-3) **(Smiths Grove only)**.

4. Commercial uses permitted in the following zoning districts:
 - a. Neighborhood Business (NB);
 - b. Office/Professional-Residential (OP-R);
 - c. Public (P);
 - d. General Business (GB) **(Smiths Grove and Woodburn only)**; and,
 - e. Highway Business (HB) **(Smiths Grove only)**.

5. Industrial uses permitted in Light Industrial (LI) zoning district **(Smiths Grove only)**.

6. Any combination of mixed uses otherwise allowed by the above specified districts in that jurisdiction.

Permitted Zoning Districts in Rural Village Overlay

Zoning District	Smiths Grove	Oakland	Woodburn
R-E	yes	yes	yes
RS-1, RM-2	yes	yes	no
RM-3	yes	no	no
NB, OP-R, P	yes	yes	yes
GB	yes	no	yes
HB	yes	no	no
LI	yes	no	no

D. Permitted Accessory Uses.

1. Barns, sheds, or other farm buildings.

Article 4

Zoning Districts – Overlay Districts

2. Residential swimming pool or detached garage or storage building.
3. Home occupations as specified in Article 5.
4. Use of a principal residence for any accessory commercial use is allowed only by first obtaining a conditional use permit.

E. Development Standards in the Rural Village Overlay.

1. **Residential Districts (R-E, RS-1, RM-2, and RM-3).**
 - a. All development shall conform to the district standards table in this Section.
 - b. The minimum front setback on all lots in residential districts shall be determined by the average of the front setbacks of all other residences on the same block face. However, in no case, shall the front setback be less than 10 feet from the right-of-way.
 - c. All permitted signs shall also comply with all the applicable Sign Development Standards in Section 4.6.8.F.
2. **Commercial Districts (NB, OP-R, GB, HB, and P)**
 - a. All development shall conform to the district standards table in this Section.
 - b. All commercial districts must be served by public sanitary sewer if located:
 - (1) in the City of Smiths Grove; or
 - (2) within 1,500 feet of public sanitary sewer at the time of application for a zoning map amendment or subdivision.
 - c. Minimum lot size for the GB, NB, OP-R, and P districts located in the cities of Oakland or Woodburn, when served by on-site septic system shall be 130,680 s.f., unless the Barren River District Health Department performs a site evaluation and determines a smaller lot will accommodate an on-site septic system and is acceptable.
 - d. The front setback shall be determined by the average of the front setbacks of all other structures on the same block face.
 - e. Maximum building size for the NB and OP-R districts shall be 2,500 s.f.

Article 4

Zoning Districts – Overlay Districts

- f. Required parking may be provided on-lot or in an off-lot communal parking area which has sufficient spaces designated for the commercial operation.
- g. All permitted signs shall also comply with all the applicable Sign Development Standards in Section 4.6.8.F.

3. Industrial District (LI)

- a. All development shall conform to the district standards table in this Section.
- b. All industrial development located in the City of Smiths Grove must be served by public sanitary sewer.
- c. All permitted signs shall also comply with all the applicable Sign Development Standards in Section 4.6.8.F.

	R-E	RS	RM-2	RM-3	NB, OP-R, P	GB, HB, LI
Minimum Lot Size on Public Sanitary Sewer (sf)	43,560	1A 13,500 1B 11,000 1C 8,000 1D 3,000	11,500	8,000 sf plus 2,500 sf for each unit >1	2,500	5,000
Minimum Lot Size with On-Site Septic (sf)	43,560*	N/A	N/A	N/A	130,680*	GB - 130,680 HB, LI - N/A
Minimum Lot Width and Lot Frontage (ft)	50	50	50	40	40	50
Maximum Lot Coverage (%)	50	1A 50 1B 50 1C 75 1D 75	90	75	90	75
Front Setback (ft)	25	10 **	**	25	0	25
Maximum Building Size (sf)	N/A	N/A	N/A	N/A	2,500	N/A
Parking Required (spaces)	2	2	2 per unit	2 per unit	1 per 500 sf	1 per 300 sf

* In R-E, NB, and OP-R, a smaller lot size with on-site septic system may occur with approval of the Barren River District Health Department only.

** In the RS-1 and RM-2 districts, the front setback is determined by the average setback of all other residential structures on that block face.

Article 4

Zoning Districts – Overlay Districts

4.9.6 Airport Overlay District

The Airport Overlay District outlines the area within proximity of the Bowling Green-Warren County Airport that is under the jurisdiction of the Kentucky Airport Zoning Commission (KAZC) (see Exhibit F in Appendix A). The underlying zoning is governed by this ordinance; however, there may be additional restrictions on development in this area placed by the KAZC. Any person developing property in this area should consult with KAZC in addition to all approvals necessary under this ordinance.

Article 4

Zoning Districts – Overlay Districts

PAGE LEFT INTENTIONALLY BLANK

**AGRICULTURAL AND RESIDENTIAL DISTRICTS
STANDARDS SUMMARY TABLE**

	AG* (pg. 4-4)	RR** (pg. 4-6)	R-E (pg. 4-6)	RS-1A (pg. 4-6)	RS-1B (pg. 4-6)	RS-1C (pg. 4-6)	RS-1D (pg. 4-6)	MHS (pg. 4-7)	MHP (pg. 4-7)	RM-2 (pg. 4-22)	RM-3 (pg. 4-22)	RM-4 (pg. 4-22)
Lot Area (min.) * Public Sewer Septic System	5 acres 5 acres	2 acres 2 acres	1 acre 1 acre	13,500 sf N/A	11,000 sf N/A	8,000 sf N/A	5,000 sf N/A	8,000 sf N/A	5,000 sf/sp N/A	11,000 sf N/A	<i>sewer only</i> 8,000 sf for first unit plus 2,000 sf for each add'l unit	<i>sewer only</i> 5,000 sf for first unit plus 1,500 sf for each add'l unit
Lot Width (min.)	100 feet	100 feet	100 feet	85 feet	75 feet	60 feet	50 feet	60 feet	50 feet	75 feet	40 feet	40 feet
Lot Frontage (min.) Public Street Cul-de-Sac	40 feet 40 feet	50 feet 40 feet	50 feet 40 feet	50 feet 40 feet	50 feet 40 feet	50 feet 32 feet	50 feet 32 feet	50 feet 32 feet	50 feet 40 feet	50 feet 40 feet	50 feet 40 feet	50 feet 40 feet
Lot Coverage (max.)	25%	25%	25%	40%	50%	60%	70%	50%	N/A	75%	75%	75%
Setbacks (min.) Front Yard Side Yard Rear Yard Accessory Structure Side Yard Rear Yard	25 feet 25 feet 10 ft (WC) 25 feet 5 feet 5 feet	25 feet 25 feet 25 feet 25 feet 5 feet 5 feet	25 feet 10 feet 25 feet 25 feet 5 feet 5 feet	25 feet 10 feet 10 feet 10 feet 5 feet 5 feet	25 feet 7.5 feet 10 feet 10 feet 5 feet 5 feet	25 feet 7.5 feet 10 feet 10 feet 5 feet 5 feet	25 feet 5 feet 10 feet 10 feet 5 feet 5 feet	25 feet 7.5 feet 25 feet 25 feet 5 feet 5 feet	50 feet 25 feet 25 feet 25 feet 5 feet 5 feet	25 feet 7.5 feet 25 feet 25 feet 5 feet 5 feet	25 feet 10 feet 25 feet 25 feet 5 feet 5 feet	25 feet 10 feet 25 feet 25 feet 5 feet 5 feet
Height	N/A	35 feet	42 feet	42 feet	42 feet	42 feet	42 feet	35 feet	35 feet	42 feet	42 feet	4 stories above grade
Min. Fire Flow Bowling Green Warren County	600 GPM 250 GPM	N/A 250 GPM	600 GPM 250 GPM	600 GPM 250 GPM	600 GPM 250 GPM	600 GPM 250 GPM	600 GPM 250 GPM	600 GPM 250 GPM	600 GPM 250 GPM	600 GPM 600 GPM	600 GPM 600 GPM	600 GPM 600 GPM
Off-Street Parking Requirement (spaces)	2 per unit	2 per unit	2 per unit	2 per unit	2 per unit	2 per unit	2 per unit	2 per unit	2 per unit	2 per unit	Bedr 1 2 3 4 Sp 1.5 2.5 3.5 4.0	Bedr 1 2 3 4 Sp 1.5 2.5 3.5 4.0

* For more information on the Agriculture District, including exceptions, see Section 4.3 on page 4-4 of the Zoning Ordinance.

**The RR (Rural Residential) District is allowed only in the unincorporated areas of Warren County.

**NON-RESIDENTIAL DISTRICTS
STANDARDS SUMMARY TABLE**

	NB (pg. 4-33)	GB (pg. 4-33)	CB (pg. 4-33)	HB (pg. 4-33)	OP-R (pg. 4-33)	OP-C (pg. 4-33)	P (pg. 4-37)	LI (pg. 4-61)	HI (pg. 4-61)
Lot Area (min.) Public Sewer Septic System *	5,000 sf 130,680 sf	5,000 sf 130,680 sf	None N/A	5,000 sf 130,680 sf	5,000 sf 130,680 sf	5,000 sf 130,680 sf	5,000 sf 130,680 sf	5,000 sf 130,680 sf	5,000 sf 130,680 sf
Lot Width (min.)	50 feet	50 feet	None	50 feet	50 feet	50 feet	50 feet	50 feet	50 feet
Lot Frontage (min.)	50 feet	50 feet	None	50 feet	50 feet	50 feet	50 feet	50 feet	50 feet
Lot Coverage (max.)	75%	75%	100%	90%	50%	75%	90%	90%	90%
Setbacks (min.) Front Yard Side Yard Rear Yard Accessory	25 feet None None None	25 feet None None None	None None None None	25 feet None None None	25 feet 10 feet 25 feet None	25 feet None None None	25 feet None None None	25 feet None None None	25 feet None None None
Height (max.)	42 feet	3 stories	4 stories	None	42 feet	6 stories	None	50 feet	100 feet
Building Size (max.) *	4,000 sf	N/A	N/A	N/A	4,000 sf	N/A	N/A	N/A	N/A
Min. Fire Flow Required	600 GPM	600 GPM	600 GPM	600 GPM	600 GPM	600 GPM	600 GPM	600 GPM	600 GPM
Off-Street Parking	See specific use chart in 4.6.8.E for parking requirements.							1 per employee (max. shift)	
Landscaping Required	See Section 4.6.8.D for landscaping standards.								
Residential Allowed? What Standard?	Yes RS-1D or Accessory	Yes RM-3 or RS-1D or Accessory Use	Yes Accessory Use	Yes Accessory Use	Yes RS-1D	Yes RM-3 or RS-1D	Yes Accessory Use	No	No

* Commercial uses with on-site septic systems are limited to a 6,000 s.f. building. This maximum building size may be increased to 10,000 s.f. if the lot area is increased to a minimum of 5 acres. Industrial uses utilizing on-site septic systems are limited to a 6,000 s.f. building.

Sign Standards Summary Table

Signage in all districts shall comply with all applicable requirements in Section 4.6.8.F unless otherwise specified in other text of the Zoning Ordinance.

	Commercial and Industrial Districts											
	AG	RE, RS, MHS	RM, MHP	NB	GB, HB	LI, HI	CB, H	OP-R	OP-C, P	PUD	UG Overlay	Univ Overlay
Freestanding Signs Allowed?	Yes *	Yes *	No	Yes	Yes**	Yes**	Yes***	Yes	Yes	Yes	Yes	Yes
Maximum No.	1*	1*	N/A	1	1**	1**	1	1	1	Per appr. Dev. Plan	See Sec. 4.9.2	1
Maximum Total Sign Face Area-Freestanding	50sf	20sf	N/A	75 sf	150 sf	100 sf	50 sf	50 sf	100 sf	Per appr. Dev. Plan	See Sec. 4.9.2	20 sf
Maximum Height	15'	5'	N/A	15'	30'	30'	15'	5'	20'	Per appr. Dev. Plan	See Sec. 4.9.2	5'
Structure Type/Restrictions	Pole or mon.	Mon.	N/A	Pole or mon.	Pole or mon.	Pole or mon.	Pole or mon.	Mon.	Pole or mon.	Pole or mon.	Monument	Monument
Wall Signs Allowed?	Yes *	Yes *	Yes *	Yes	Yes	Yes	Yes***	Yes	Yes	Yes	Yes	Yes
Maximum Total Sign Face Area-Wall Signs	50 sf	12 sf	40 sf	100 sf or 5% of Facade, whichever is greater	100 sf or 10% of Facade, whichever is greater	100 sf or 10% of Facade, whichever is greater	100 sf or 5% of Facade, whichever is greater	50 sf or 5% of Facade, whichever is greater	100 sf or 5% of Facade, whichever is greater	100 sf or 10% of Facade, whichever is greater	See Sec. 4.9.2	32 sf

* In Agriculture and Residential Districts, freestanding and wall signs are allowed for properly permitted conditional uses only.

** These Commercial Districts **MAY** have a second high-rise sign, if within the area permitted for Interstate High-Rise Signs (See Appendix A-Exhibits A, B and B1).

Section 4.6.8.F.7.(b) outlines sign heights and square footage requirements for all high-rise signs.

*** Signs within any Historic District must first obtain a Certificate of Appropriateness from the Historic Preservation Board.

[PAGE LEFT INTENTIONALLY BLANK]